

LAUNCH

TLT245AT/TLT250AT(C)

Two Post Lift User's Manual

Version No:1707

Copyright reserved! Without the written agreement of Launch Shanghai Machinery Co., Ltd. (hereinafter called "Launch"), no company or individual is allowed to copy and backup this manual in any form (electronic, mechanical, photocopy, recording or other forms). This manual is specifically designed for the use of Launch product, and our company doesn't undertake any responsibility for various consequences caused as a result of applying it to the guidance of operating other equipment.

In case of the equipment damage or loss due to the accident of the user himself or third party, abuse or misuse of this equipment, unauthorized change and repair of this equipment, or not conforming to the operation and maintenance requirement of Launch, Launch and its branches won't undertake any responsibility for the expenses and expenditures generated.

For the equipment damage or problem caused as a result of using other optional accessories or consumables instead of original Launch product or its recognized product, Launch won't undertake any responsibility.

Official statement: The purpose of other- product- names mentioned in this manual is to describe how to use this equipment. Their registered trademarks still belong to the original companies.

This equipment is for the use of professional technical personnel or maintenance personnel.

## Registered Trademark

Launch has registered its trademark in China and several foreign countries, with the symbol of LAUNCH. Other trademarks, service symbol, domain name, icon, and company name of Launch mentioned in this manual belong to the property of Launch and its subsidiary companies. In the countries where Launch's trademark, service symbol, domain name, icon and company name haven't been registered, Launch declares its ownership on such unregistered trademark, service symbol, domain name, icon and company name. The trademarks of other products and company names mentioned in this manual still belong to the originally registered companies. Without prior written agreement of the owner, nobody can use the trademark, service symbol, domain name, icon and company name of Launch and other companies mentioned in this manual. If you have any question, please visit website of Launch: <http://www.cnlaunch.com> or write to Sales Dept. of Launch Shanghai Machinery Co., Ltd. at No. 661 Baian Road, International Automobile City Auxiliary Parts Park, Anting Town, Jiading District, Shanghai City to contact Launch.

## Insured by PICC

## WARNING



## WARNING

- This instruction manual is an essential integral part of this product. Please read all instructions.
- Properly keep this manual for use during the maintenance.
- This equipment is only used for its clearly designed purpose, and never use it for other purposes.
- The manufacturer is not responsible for any damage caused by improper use or other purposes of use.

## PRECAUTION

- Only the qualified personnel having undergone special training can operate this machine. Without the permission of the manufacturer or not following the requirement of the manual, any changes in the machine part and in the usage scope may cause direct or indirect damage to the machine.
- Don't keep the lift in the extreme temperature and humidity environment. Avoid installation beside the heating equipment, water tap, air humidifier or stove.
- Prevent the lift from contacting large amount of dust, ammonia, alcohol, thinner or spray adhesive, and prevent it from rain shower.
- During the machine operation, non-operators should be kept away from the machine.
- Inspect machine daily, do not use lift with damaged parts or being damaged. Use original components to replace damaged parts

- The lift can't be overloaded. The rated load of the lift is already marked on the nameplate.
- Please don't raise the lift when there are people in the vehicle. During the operation, the customer and spectators shouldn't stand in the lifting area.
- Keep the lifting area free from obstacle, grease, machine oil, garbage and other impurities.
- Position the swing arm of the lift, making it contact the lifting point as recommended by the manufacturer. Raise the carriage and confirm the lifting pad and vehicle are closely contacted. Raise the carriage to the appropriate working height.
- For some vehicles, the parts dismantling (or installation) will cause severe deviation of the center of gravity, leading to unstable vehicle. The support is needed to keep the balance of the vehicle.
- Before moving the vehicle away from the lifting area, please position the swing arm and lifting pad back away to avoid blockage during the movement.
- Use appropriate equipment and tools as well as safety protection facilities, e.g. working uniform, safety boot, etc.
- Pay special attention to various safety marks attached to the machine body.
- Keep hair, loose clothing, fingers, and all parts of body away from moving parts
- Pay special attention not to dismantling the safety unit of the machine or making it not functioning.
- The hydraulic oil used for this lift is N32 or N46. Please refer the safety data of grease and oil shown in the manual.
- Let components cool down before storage, loosen component cables completely in storage
- Do not install lift in the open air or expose to rain, special requirements should be offered to manufacturer if it can't be avoided.
- Carefully check equipment list before installation. Immediately connect distributor or Launch for any question.
- Launch Shanghai Machinery Co., Ltd. is dedicated to continuously improving the product quality and upgrading the technical spec. They are subject to change without notice.

## Caution Labeling Exemplification

- (1) Read operating and safety manuals before using lift!



- (6) Use vehicle manufacture's lifting points!

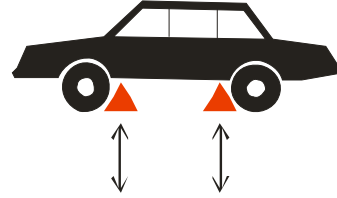

- (2) Proper maintenance and inspection is necessary for safe operation!



- (7) Use bracket to help disassembly or installation!



- (3) Don not operate a damaged lift !



- (8) Auxiliary adapters would reduce load capacity!

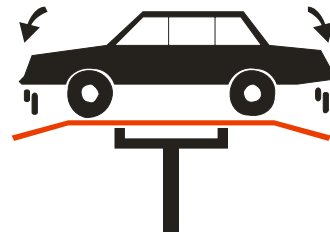

- (4) Lift can be used by trained operators ONLY!



- (9) Area should be unimpeded in case of vehicle overturn!



- (5) Only Authorized personnel can be in the lift area!



- (10) The central of gravity should be between two arms!



(11) Keep area clear when lifting and lowering machine!



(14) Keep feet away when lowering lift!



(12) Do not shake the vehicle on the lift !



(15) Do not stand under carrying arms or other load carrying device while lift is being operated with load!



(13) Do not lift single side of vehicle!



## Table of Contents

1 Outline.....	1
1.1 Model Description.....	1
1.2 Purpose .....	1
1.3 Functions and Features.....	1
1.4 Technical specifications.....	1
1.5 Environmental Requirement .....	2
2 Lift Structure .....	2
3 Operation Description.....	5
3.1 Precautions for vehicle repair work.....	5
3.2 Preparation before Operation.....	5
3.3 Lifting the Vehicle.....	5
3.4 Lowering the Vehicle.....	5
4 Solutions to FAQ.....	6
5. Repair and Maintenance.....	7
6.Storage and Scrap.....	8
6.1 Storage.....	8
6.2 Scarp.....	8
Grease and hydraulic oil for lift.....	9
Diagram of electrical system.....	10
Diagram of the hydraulic system.....	11

# 1. Outline

## 1.1 Model Description

Model	Description
TLT245AT clear-floor 2-post lift	4.5T economical clear-floor 2-post lift
TLT250AT(C) clear-floor 2-post lift	5T economical clear-floor 2-post lift

## 1.2 Purpose

TLT245AT/TLT250AT(C) are of safe and simple operation and applicable for the lifting of various small and medium-sized vehicles with total weight below 4.5/5t in garage and workshop

## 1.3 Functions and Features

- The cable and oil pipe are fully concealed, with decent and elegant appearance.
- Designed based on the international standard, meeting the demand of the garage and workshop.

- Top limit switch, effectively protecting the vehicle from overhead collision.
- Dual hydraulic cylinders drive, stable lifting and lowering.
- Automatic full-scope safety lock, safe and simple in operation.
- Adopt two steel cables for equalization, force two carriages to move synchronously, and effectively prevent the vehicle from tilting.
- Lowest height of lifting pad is 110mm, good for repairing low chassis or low profile car.

## 1.4 Technical Specifications

Basic parameters of the equipment:

Model	Rated load	Lifting height	Rising time	Descending time	Net weight	Passing width	Machine width	Machine height
TLT245AT (symmetric installation)	4500 kg 10000 lb	1850 mm 72.8 in	≤50s	≥20s ≤40s	720kg 1587 lb	2486 mm 97.9 in	3420 mm 134.6 in	3840 mm(151.2 in) Optional: 4300mm/4150mm (169.3in /163.4in)
TLT245AT (asymmetric installation)						2415 mm 95.1 in	3563mm 140.3 in	
TLT250AT(C) (symmetric installation)	5000 kg 11000 lb	1850 mm 72.8 in	≤50s	≥20s ≤40s	960kg 2116 lb	3050mm 120in	4110mm 161.8in	4810mm(189.4in) Optional: 4150mm(163.4in)
TLT250AT(C) (asymmetric installation)						2888mm 113.7in	4130mm 162.6in	

Noise:

Working noise: ≤ 75dB (A)

### Power unit

Working pressure: 18MPa TLT245AT  
20MPa TLT250AT(C)

Electrical parameters of the machine:

Motor (optional)

Voltage: According to client's requirement

Single phase: 110V /60Hz ; 220V/50Hz

Single phase: 200V/ 60Hz

Three phase: 380V/50Hz

Power: 2.2kW TLT245AT 3 kW TLT250AT(C)

### 1.5 Environmental Requirement

Working temperature: -5°C ~ +40°C

Relative humidity: Temperature +30°C , relative humidity 80%

Transport/storage temperature: -5°C ~ +40°C

Height above sea level: No more than 2000m

### 2. Lift Structure

TLT245AT structure is shown as Fig1, Fig2a, Fig3a:

TLT250AT(C) structure is shown as Fig1, Fig2b, Fig3b:

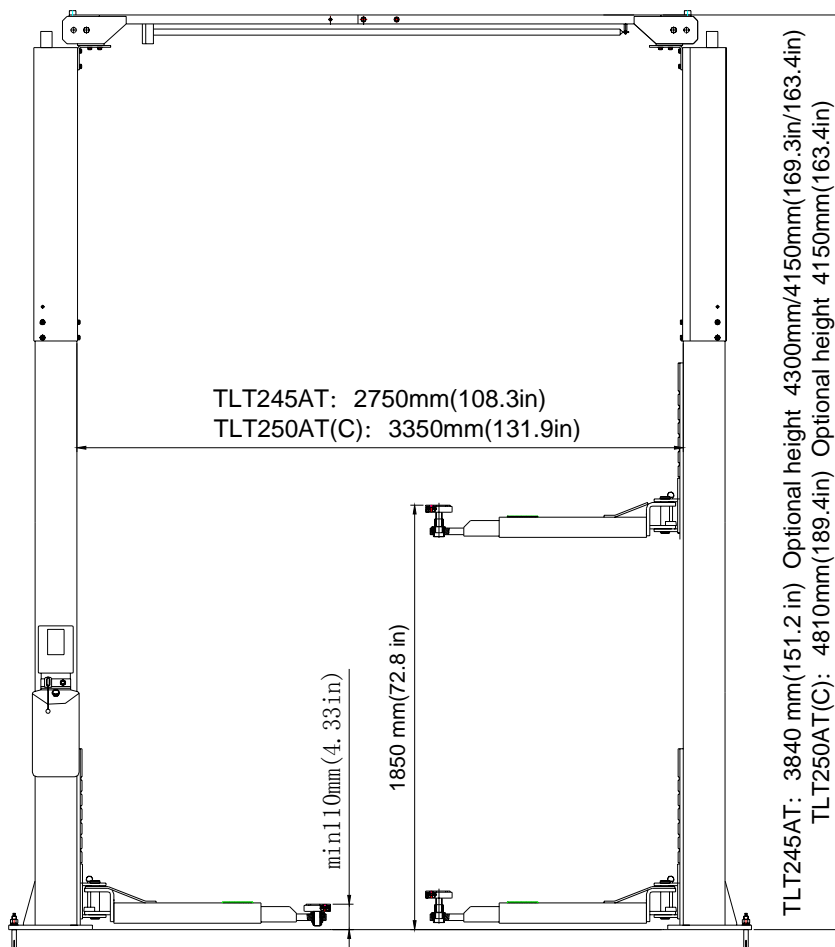

Fig 1



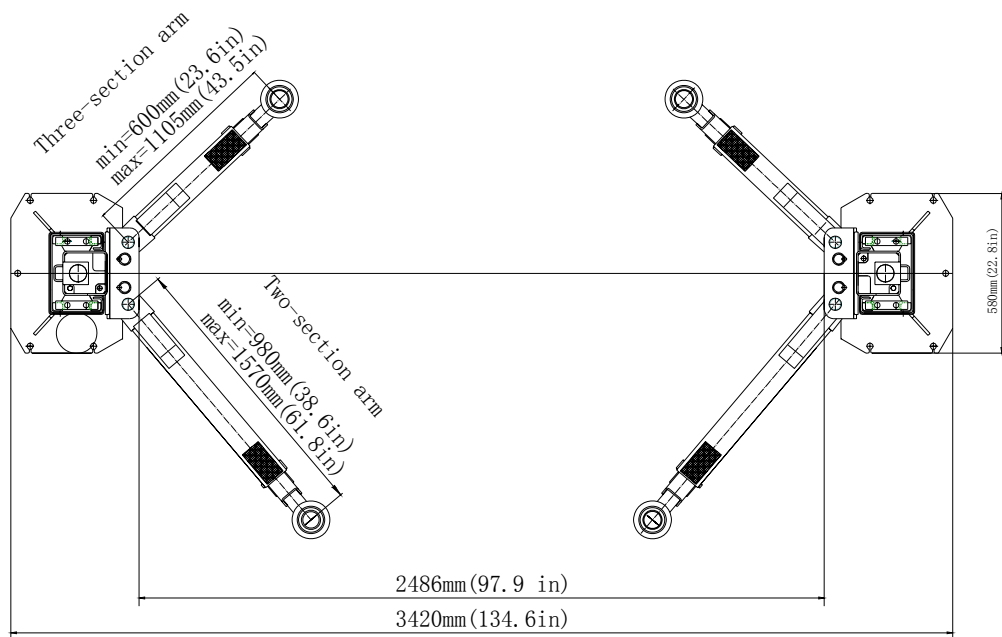

Fig.2a

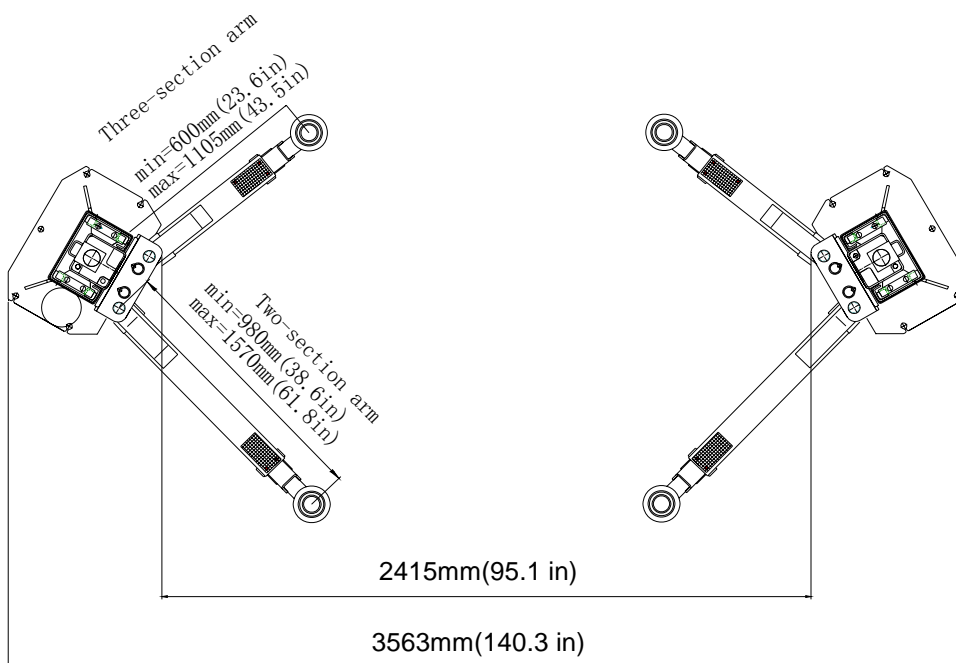

Fig.3a

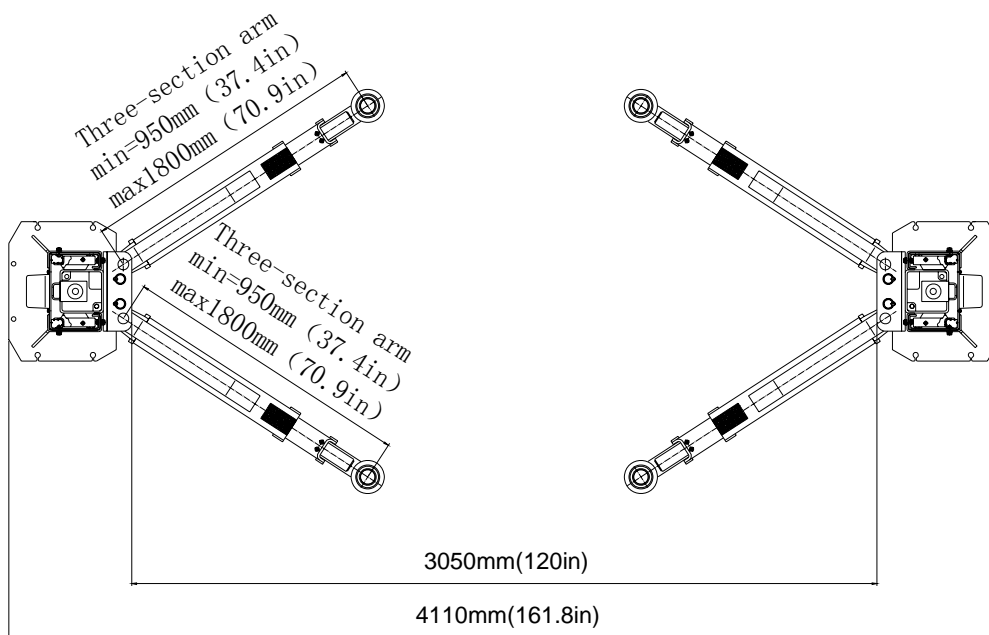

Fig.2b

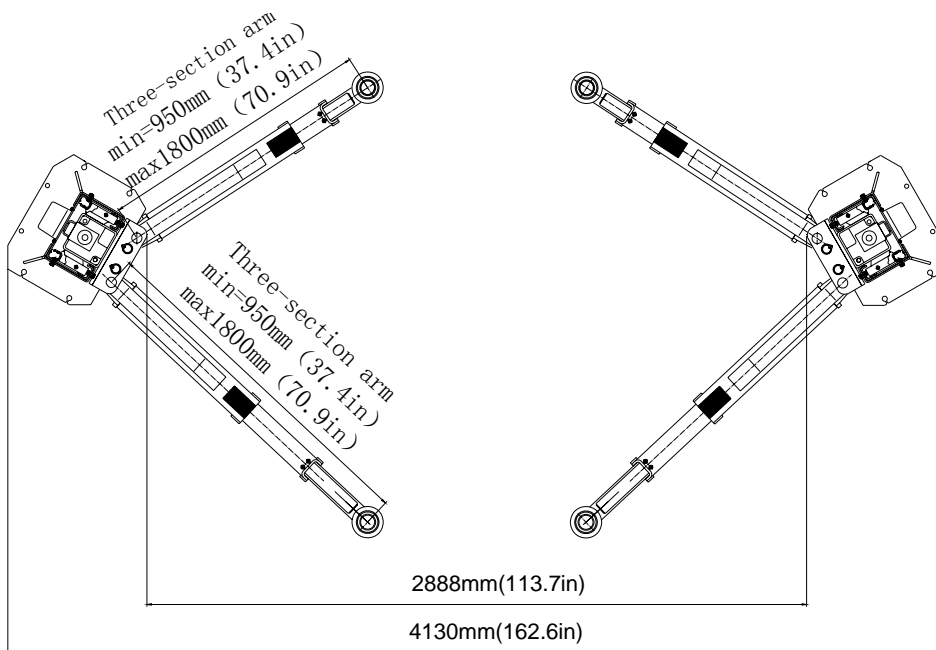

Fig.3b

## 3. Operation Description

### 3.1 Precautions for vehicle repair work

- Different vehicles have different center of gravity positions. First understand the position of center of gravity, and when the vehicle enters into the lift, make its center of gravity close to the plane formed by two columns. Use vehicle manufacture's lifting points!.
- Cautiously note the car roof position when lifting, to avoid its contacting with top beam and causing accident.
- Carefully read the warning symbol.
- The hydraulic valves have been adjusted before ex-factory, and the user can't make self-adjustment, otherwise it will be responsible for all the consequences generated.
- Based on the production needs, some specifications in the instruction manual are subjected to change without notice

### 3.2 Preparation before Operation

- Lubricate contact surface of the carriage with general-purpose lithium grease (GB7324-87) . All sliding surface should be coated evenly from the top to bottom.
- Fill hydraulic oil N32 or N46( approx.12L ) to the oil reservoir of the power unit.

### 3.3 Lifting the Vehicle

- Keep work area clean, don't operate the lift in cluttered work area.
- Lower the carriage to the lowest position.
- Reduce the swing arm to the minimum length.
- Swing the arm along the route of the vehicle
- Move the vehicle to the location between the two columns
- Swing the arm and put the lifting pad below the recommended lifting point, and adjust the height of lifting pad to touch lifting point of vehicle
- Press the UP button on the electric control box(Fig.4), slowly lift the vehicle to ensure the load balance, and then raise the lift to the required height.
- Release the UP button and the carriage will stop.
- Press the DOWN button to engage the safety lock of carriage. At this time, the vehicle can be repaired.



Note:

- ◇ Before operation, the safety locking devices must be Inspected.1) The gear blocks of the arm end must engage the gear block of the

restraint shaft.2)No broken strand in the steel cable. 3)No deformation in the arm pad.

- ◇ When lifting the vehicle, all the swing arms must be used.
- ◇ Before lifting the vehicle, check all the hydraulic hose and fittings for oil leakage. In case of leakage, please don't use the lift. Remove the fitting with leakage and re-seal. Re-install the fitting and check if oil leakage still exists.
- ◇ After the vehicle is lifted, when adding or removing any major heavy object, use jack stand to maintain the balance of the vehicle.

### 3.4 Lowering the Vehicle

- Clean the work area before lowering the vehicle.
- Lift vehicle of 5-10mm.
- Pull the safety lock handle, then press down the lowering handle(Fig.4),the carriage lowers
- Lower the vehicle till the swing arm down to the bottom and the lifting pads leave the vehicle chassis, and then release the handle.
- The swing arms under the vehicle must be fully shrunk.

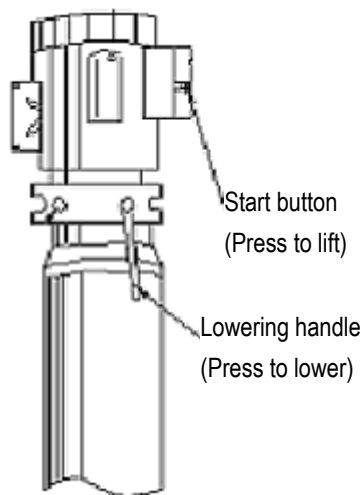

Fig 4



Note: Don't operate lift if the safety latch

doesn't work, which means the safety latch must fall into the safety groove when lifting. Don't operate lift when the load is tilting.

## 4. Solutions to FAQ

Symptom	Reason	Solution
Motor not operation	<ul style="list-style-type: none"> <li>◆ Start-up button is broken</li> <li>◆ Limit switch burnt out</li> <li>◆ Motor burnt out</li> </ul>	<ul style="list-style-type: none"> <li>◆ Change UP button</li> <li>◆ Change switch</li> <li>◆ Change Motor</li> </ul>
Motor is running, but the lift can't be raised.	<ul style="list-style-type: none"> <li>◆ Hydraulic pump sucks the air</li> <li>◆ Suction tube is separate from the hydraulic pump</li> <li>◆ Low oil level</li> </ul>	<ul style="list-style-type: none"> <li>◆ Fasten all the suction pipe fittings</li> <li>◆ Replace the suction tube</li> <li>◆ Add the oil into the oil tank</li> </ul>
Motor is running, the lift can be raised without load, but the vehicle can't be raised	<ul style="list-style-type: none"> <li>◆ Motor is running under low voltage</li> <li>◆ Impurities inside the solenoid valve body</li> <li>◆ Regulation pressure of safety valve is incorrect</li> <li>◆ Lift is overloaded</li> </ul>	<ul style="list-style-type: none"> <li>◆ Supply correct voltage to the motor</li> <li>◆ Remove impurities from the solenoid valve body.</li> <li>◆ Adjust the safety valve</li> <li>◆ Check the weight of the vehicle</li> </ul>
The lift is lowering slowly	<ul style="list-style-type: none"> <li>◆ Leakage on the solenoid valve body.</li> <li>◆ External oil leakage</li> </ul>	<ul style="list-style-type: none"> <li>◆ Clean the solenoid valve body</li> <li>◆ Repair the external leakage</li> </ul>
The lifting speed is slow or oil flows out of the oil fill cap	<ul style="list-style-type: none"> <li>◆ Air and oil are mixed</li> <li>◆ Oil return pipe is loosened</li> </ul>	<ul style="list-style-type: none"> <li>◆ Replace the hydraulic oil or start when air is out</li> <li>◆ Re-install the oil return pipe</li> </ul>
The lift can't rise horizontally	<ul style="list-style-type: none"> <li>◆ Balance cable is not adjusted properly</li> <li>◆ The lift is installed on the slop floor</li> </ul>	<ul style="list-style-type: none"> <li>◆ Adjust the balance cable to the proper tension</li> <li>◆ Shimming the columns to level the lift(no more than 5mm), If exceeding 5mm, pour new concrete floor to make it level. Refer to installation description.</li> </ul>
Anchor Bolt is not fastened	<ul style="list-style-type: none"> <li>◆ Hole is drilled too big</li> <li>◆ Concrete floor thickness or fastening force is insufficient</li> </ul>	<ul style="list-style-type: none"> <li>◆ Pour the fast curing concrete into the big hole and reinstall the anchor Bolt , or use new drill to drill the hole for re-positioning the lift</li> <li>◆ Cut open the old concrete and make new concrete slab for the lift. Refer to installation description.</li> </ul>

## 5. Repair and Maintenance

### Keep clean

- This unit should be cleaned with dry cloth frequently to keep it clean. Before cleaning, first switch off the power to ensure the safety.
- The working environment of this unit should be clean. In case of dust in the working environment, it will speed up the parts wearing and shorten the service life of the lift.

### Every day:

- Check to see if the connection between hydraulic cylinder and carriage is proper.
- Check to see if the steel cable connection is proper, and if the tension is at the optimum status.

### Every month:

- Retighten the anchor Bolt s.
- Lubricate chains/cables with lithium based lubrication grease (GB7324-87)
- Check all the hydraulic lines for wearing
- Check to see if the carriage and the inner side of the column are properly lubricated. Use high-quality heavy lubrication grease (lithium based lubrication grease GB7324-87).

 *Note: All the anchor Bolt s should be tightened completely. If any Screw doesn't function for some*

*reason, the lift can not be used until the Bolt is replaced*

### Every six months:

- Check all the movable parts for possible wearing, interference or damage.
- Check the lubrication of all the pulleys. If the pulley has dragging during the lifting and lowering, add appropriate lubricant to the wheel axle.
- When necessary, check and adjust the balancing tension to ensure the horizontal lifting and lowering.
- Check the verticality of the column.

 *Note: The inner corner of each column should be lubricated with lubricant, to minimize the roller friction and ensure the smooth and even lifting.*

### Maintenance of hydraulic system:

- Clean and oil change  
In the six months after initial use of this unit, clean the hydraulic oil tank and replace the oil, later clean the hydraulic system once a year, and replace the oil.
- Replace the seal  
After this unit is put into operation for certain period, if finding the oil leakage, carefully check it; if the leakage is due to the wearing of sealing materials, immediately replace the worn one based on the original spec. See Fig. 7

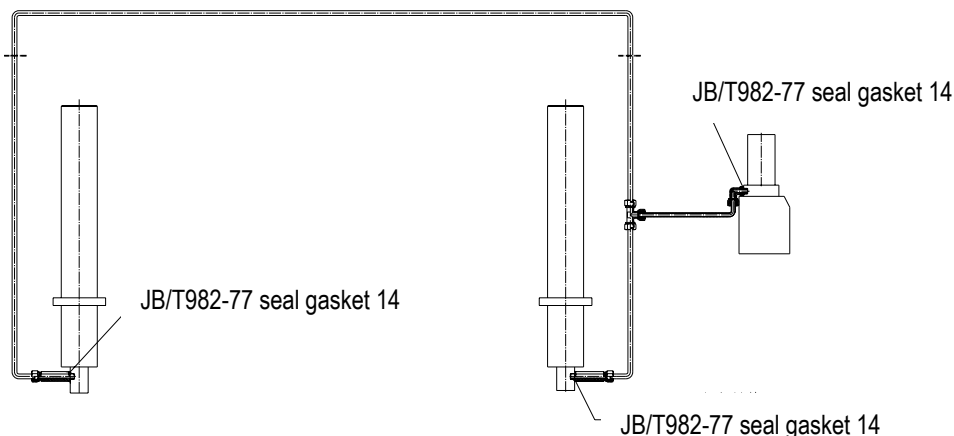

Fig.7

## 6. Storage and Scrap

### 6.1 Storage

When the equipment requires long-time storage:

- Disconnect the power supply
- Lubricate all the parts requiring lubrication: mobile contact surface of the carriage, etc.
- Empty all the oil/liquid storage units
- Put the plastic cover over the equipment for dust protection

### 6.2 Scarp

When the equipment service life is expired and can no longer be used, disconnect the power supply, and properly dispose of as per relevant local regulations.

## Grease and hydraulic oil for lift

### 2# lithium based lubrication grease

Item	Quality Index
Conical degree (1/10mm)	278
Dripping point/°C	185
Corrosion (T2 copper sheet, 100 °C, 24h)	No change for copper sheet
Copper mesh oil split (100°C, 22h) %	4
Evaporation (100°C, 22h) %	2
Oxidation stability (99°C, 100 h)	0.2
Anti-corrosion (52°C, 48)	Class 1
Impurity (microscope) / (pcs/cm <sup>3</sup> )	
Above 10µm no more than	5000
Above 25µm no more than	3000
Above 75µm no more than	500
Above 125µm no more than	0
Similar viscosity (-15°C, 10s <sup>-1</sup> ) ,(Pa·s) no more than	800
Water spray loss (38°C, 1h) (%) no more than	8

### N32 hydraulic oil (used for low ambient temperature)

Item	Quality Index
Kinematic viscosity 40°C	28.8~35
Pour point /°C no higher than	-15
Flash point /°C no lower than	175

### N46 hydraulic oil (used for high ambient temperature)

Item	Quality Index
Kinematic viscosity 40°C	41.4~50.6
Pour point /°C no higher than	-9
Flash point /°C no lower than	185

### Diagram of electrical system

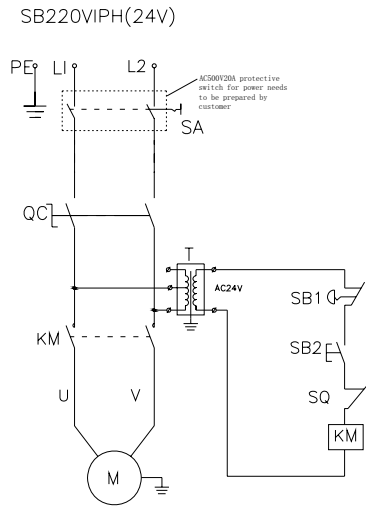

M–Motor KM–Contactor SB1–Emergency Stop Switch  
 SB2–Button SQ–Limit switch T–Transformer

**Diagram of single-phase motor**

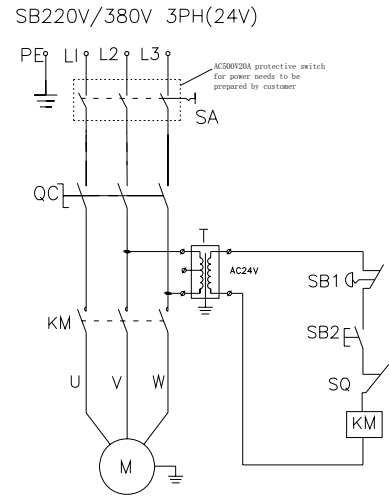

M–Motor KM–Contactor SB1–Emergency Stop Switch  
 SB2–Button SQ–Limit switch T–Transformer

**Diagram of three phase motor**

The electrical working principle is as follows:

Press the start button (SB), motor (M) is energized to drive the gear pump supplying oil to push the carriage upward; release the start button SB, the motor (M) will lose

the power and the carriage will stop rising. if the vehicle is lifted up to the top and contacts the limit switch (SQ) on the top beam, the motor (M) will lose the power, the carriage will stop lifting to protect the roof.



**Diagram of hydraulic system:**

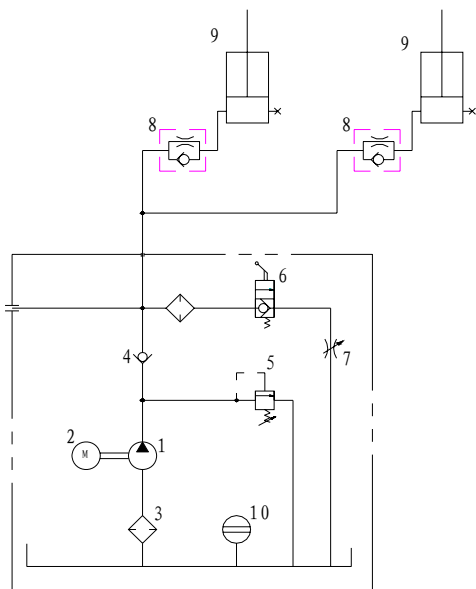

**Working principles of hydraulic system:**

When the button is pressed to start the motor on the power unit, the motor 2 will be actuated to put the oil pump 1 into motion; and oil will be sucked from the oil tank and sent to cylinder 9 forcing the piston move upward. At this time, the safety vale 5 is closed. (The pressure is well adjusted before leaving the factory to ensure the rated capacity. However, when the system pressure exceeds the limit, the oil will automatically overflow). When the start button is released, the oil supply will stop so as to stop the lifting. For lowering the carriage, first start up the motor to raise the carriage a little, pull the safety lock handle on the column to disengage the safety locking status; and then press the manual lowering handle valve 6 to lower the carriage.

## Warranty

This warranty clause is only applicable for the users and distributors who purchase LAUNCH products through normal sales procedure.

Within 12 months from the date of goods delivery, Launch will make warranty on its mechanical and electrical components due to material or process defects. This warranty does not extend to defects or damage caused by ordinary wear, abuse, unauthorized change, misuse, shipping damage, or lack of required maintenance. The compensation for the automobile damage caused by our equipment defect is only restricted to repair, and Launch doesn't undertake any indirect or incidental loss. Launch will judge the equipment damage attribute based on its stipulated inspection method. None of Launch's distributors, staffs or commercial representatives has the right to make any confirmation, prompting or commitment related to Launch's products.

## Disclaimer

The above warranty clause can replace any other forms of warranty clauses.

## Order notice

The parts and optional accessories that can be replaced can be directly ordered with suppliers authorized by Launch. When placing the order, please indicate:

Order quantity

Parts number

Parts name

## Customer service

In case of any problems during the operation of the equipment, please call: 86-21-69573179 or toll free number 8008206369.

Please send the equipment that needs repair to manufacturer attached with warranty card, manufacturer's certificate, purchase invoice and problem description. Repair would be free of charge and freight fee would be returned if the equipment is under warranty, if not, repair would be charged and we don't bear freight cost. The following is the address of the lift production base of Launch Shanghai:

No. 661 Baian Road, International Automobile City Auxiliary Parts Park, Anting Town, Jiading District, Shanghai City

Launch Shanghai Machinery Co., Ltd.

Postcode: 201805



# LAUNCH

## TLT245AT/TLT250AT(C)

### Two Post Lift

### Installation & Adjustment Manual

Version No: **1707**

# Table of contents

1. Precaution.....	1	5.2.6 Install and adjust the balancing steel cables.....	10
2.Lift Structure.....	2	5.2.7 Install the power unit.....	11
2.1 Diagram of lift structure.....	2	5.2.8 Connecting the power supply.....	11
2.2 Principle of the equipment.....	5	5.2.9 lock release cable installation.....	12
3 Tools for installation and adjustment.....	5	5.2.10 Connecting the hydraulic lines.....	12
4. Unpacking.....	6	5.2.11 Install the swing arm and guardrail.....	13
5. Installation.....	6	6. Lift Adjustment.....	14
5.1 Important notice.....	6	6.1 Preparation before adjustment.....	14
5.2 Installation Procedure.....	6	6.2 Adjustment procedure.....	14
5.2.1 Selecting installation site .....	6	7. List of the lift components.....	15
5.2.2 Base plate layout.....	7	7.1 TLT245AT components list.....	15
5.2.3 Install the powerside column.....	8	7.2 TLT250AT(C) components list.....	22
5.2.4 Install the top beam.....	9	Diagram of the electrical system.....	29
5.2.5 Install the offside column.....	10	Diagram of the hydraulic system.....	30
		Appendix: Transportation Guide.....	31

# 1. Precaution

## WARNING

- This instruction manual is an essential integral part of this product. Please read all instructions.
- Properly keep this manual for use during the maintenance.
- This equipment is only used for its clearly designed purpose, and never use it for other purposes.
- The manufacturer is not responsible for any damage caused by improper use or other purposes of use.

## PRECAUTION

- Before the installation and adjustment, carefully read this manual and the user's manual. Without the permission of the manufacturer or not following the requirement of the manual, any changes on the machine parts and its usage may cause direct or indirect damage to the machine and injury on operators.
- To do the installation and adjustment, the personnel must have certain electrical knowledge.
- The operators must undergo special training and are qualified.
- Fix and install the lift on the stable concreted floor.
- The lift shall be installed in a sufficient space so that the operation is not restricted.
- Don't expose the lift to the extreme temperature and humidity environment. Avoid installation beside the heating equipment, water tap, air humidifier or stove.
- Don't install the lift in front of the window where the sunlight can shine directly. When it's unavoidable, use curtain to shield the sunlight.
- The manufacturer reserves the right to make design changes or add improvements to its product line without notice.
- Before installation, carefully check the packing list of lift. In case of any question, please contact the distributor or LAUNCH immediately
- Launch Shanghai Machinery Co., Ltd. is dedicated to continuously improving the product quality and upgrading the technical spec. They are subject to change without notice.

## 2. Lift Structure

### 2.1 Diagrams of Lift structure

TLT245AT structure is shown as Fig1, Fig2a, Fig3a:

TLT250AT(C) structure is shown as Fig1, Fig2b, Fig3b:

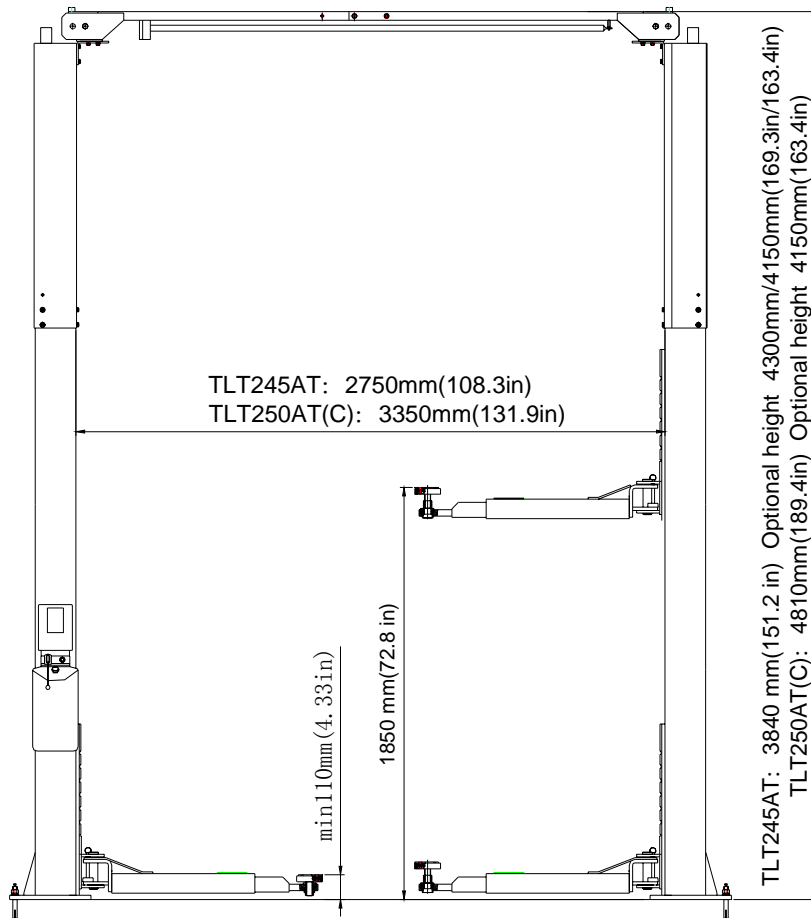

Fig 1

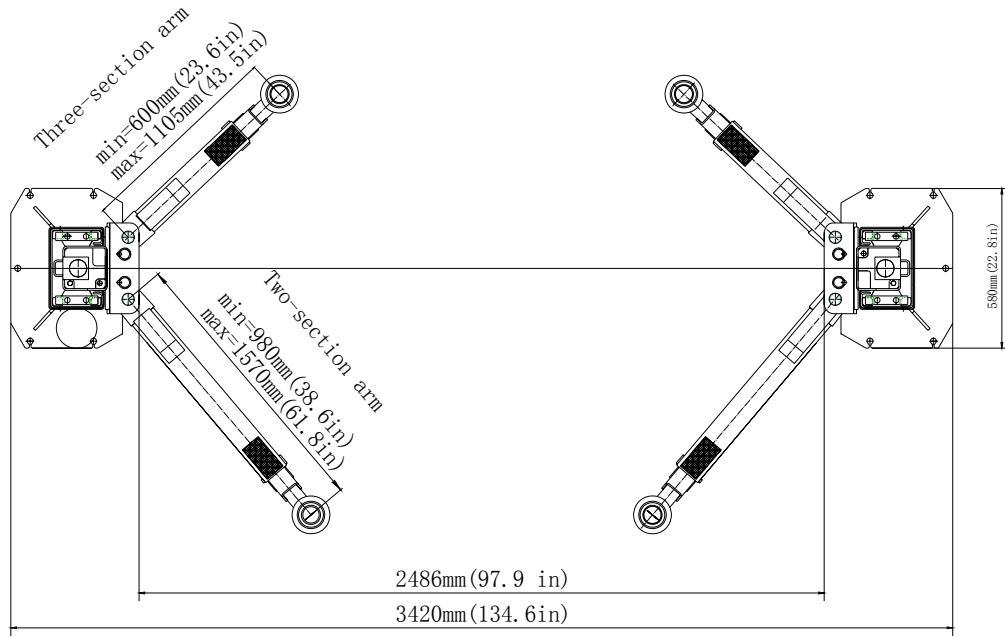

Fig.2a

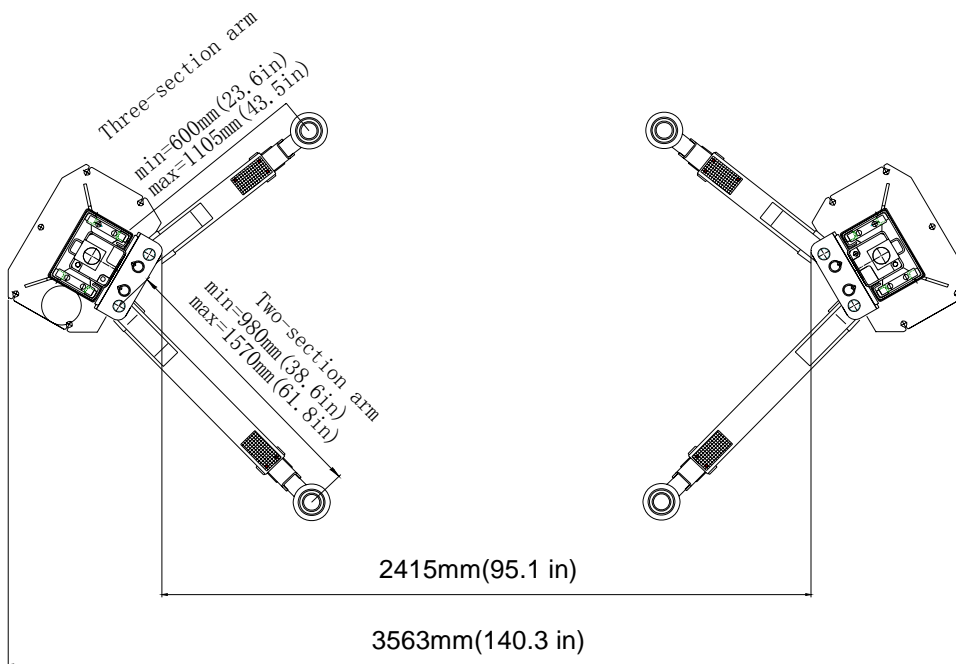

Fig.3a



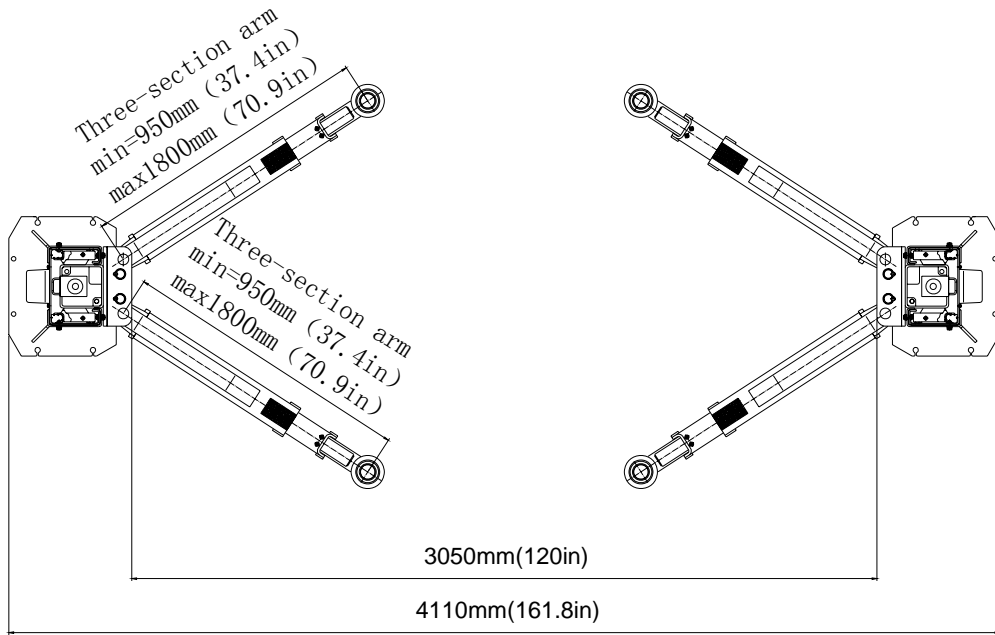

Fig.2b

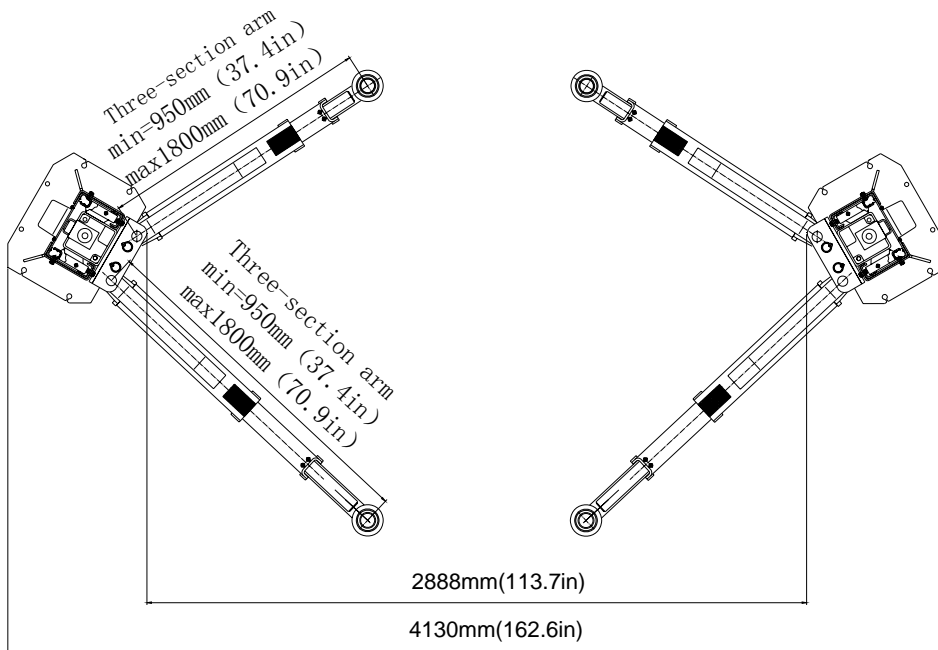

Fig.3b

## 2.2 Principles of equipment

- Lifting mechanism: Each of the two columns has one hydraulic cylinder respectively. When the power unit works, the hydraulic oil gets into the lower chamber of the cylinder, forcing the piston rod moves upward and drive the carriage moving upward .
- Supporting mechanism: When the vehicle enters into the working area, adjust the position of two-stage telescopic swing arms to make the lifting pad near the correct lifting point of the vehicle, and then adjust the screw height below the pad to adapt to different heights of vehicle chassis.
- Balancing mechanism: To keep the balance during the lifting and lowering process, the lift uses two steel cables to interconnect two carriages, forcing the carriages to rise and descend synchronously. If the carriages and swing arms are not on the same level, adjust the screw at the end of the steel cable, making the swing arms at the same level (equal position from the floor). At this time, the steel cables must be adjusted tightly with equal tension, otherwise the equalization can't be ensured.
- Manual safety lock system: Two safety plates are installed on each of the column and safety boards are welded on the back of the carriages. When the carriages rise, safety boards will go up and push against the safety plates .When the carriages stop, the safety plates will get into the slot of the safety boards to prevent the carriages from lowering; when lowering the carriage, lift carriages a little to disengage safety plate and then pull the lowering handle on power unit to lower the carriages
- Safety lock scope: The effective travel range of safety lock mechanism is from 470mm to 1900mm,the distance between the lifting pad and ground.
- To prevent the vehicle slip, the swing arm is installed with positioning mechanism, making the swing arm capable of automatic locking during operation.

## 3. Tools for installation and adjustment

To ensure proper installation and adjustment, please prepare the following tools:

Tool	Model
Leveling instrument	Carpentry type
Chalk line	Min 4.5m
Taper Plunger Chip	
Hammer	1.5kg
Tweezer	Small type
Crescent wrench	40mm
Open-end wrench set	11mm-23mm
Ratchet socket set	
Flat screwdriver	150mm
Rotary hammer drill	20mm
Concrete drill-bit	
4 feet bubble level	

## 4. Unpacking

- Open the packing box; remove the packing materials and inspect the lift for any sign of shipment damage. Check packing list to see if the main parts and accessories are complete.
- Keep the packing materials away from the children to avoid danger; if the packing materials cause the pollution, they shall be treated properly.

## 5. Installation

### 5.1 Important notice

- The wrong installation will cause the lift damage or personal injury. The manufacturer will not undertake any responsibilities for any damage caused due to incorrect installation and usage of this equipment, whether directly or indirectly.
- The correct installation location shall be "horizontal" floor to ensure the horizontal lifting. The slightly slope floor can be corrected by proper shimming. Any big slope will affect the height of the lifting pad when at the bottom or the horizontal lifting. If the floor is of questionable slope, consider a visual inspection, or pour a new horizontal concrete slab if possible. In short, under the optimum horizontal lifting status, the level of the lifting relies on the level of the floor where it is installed. Don't expect to compensate for the serious slope.
- Don't install this lift on any asphalt surface or any surface other than concrete. The lift must be installed on concrete conforming to the minimum requirement showed in the manual. Don't install this lift on the concrete with seams or crack and defect. Please check together with the architect.

- Without the written approval of the architect, don't install this lift on a second floor with basement.
- Overhead obstruction: The lift installation area can't have any overhead obstruction, such as heater, building support, electrical pipe, etc.
- Concrete drilling test: The installation personnel can test the concrete thickness at each site by drilling test. If several lifts are installed at one place, it is preferred to make drilling test in each site
- Power supply: Get ready the power supply before the installation. All the electric wiring and connecting should be performed by a certified electrician.

### 5.2 Installation procedure

#### 5.2.1 Selecting installation site

Select installation site based on the following conditions:

- Lift can only be installed on concrete slab, which must have a minimum thickness of 250mm and should be aged 7days at least .
- The concrete slab shall have reinforcement by steel bar.
- The concrete slab must be leveled.
- If the thickness of the whole ground concrete is greater than 250mm, the lift can be installed directly
- Check the possible obstruction, e.g. low ceiling, top pipeline, working area, passage, exit, etc.
- The front and back of the lift should be reserved with sufficient space to accommodate all the vehicles(Fig.4).

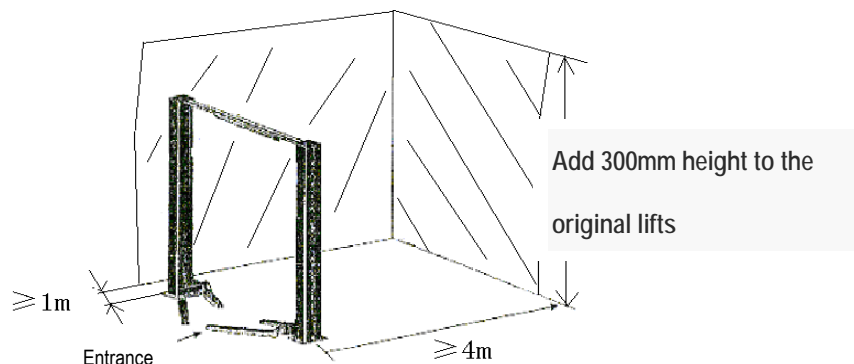

Fig 4

**5.2.2 Base plate layout**

TLT245AT base plate installation is shown in Fig5a,  
TLT250AT (C) base plate installation is shown in Fig5b:

- With total width (A) as the basis, draw two parallel lines (#1 and #2) on the concrete slab, with the error within 3mm.

- Determine the power side column location on any chalk line, and mark the total width (B) of the base plate. Mark the points 3 and 4
- Starting from point 3, draw one diagonal line (C), forming a triangle. In this way, the vertical lines can determine the location of the two columns

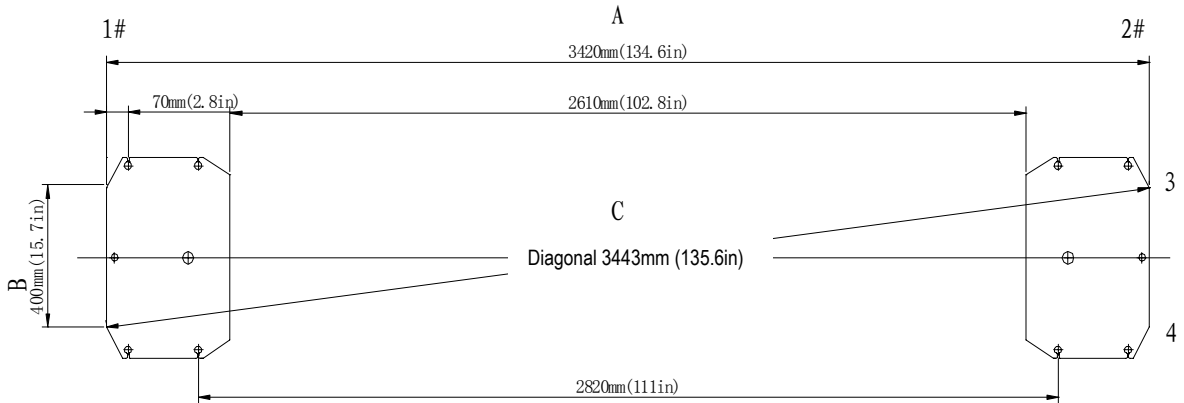

Fig 5a

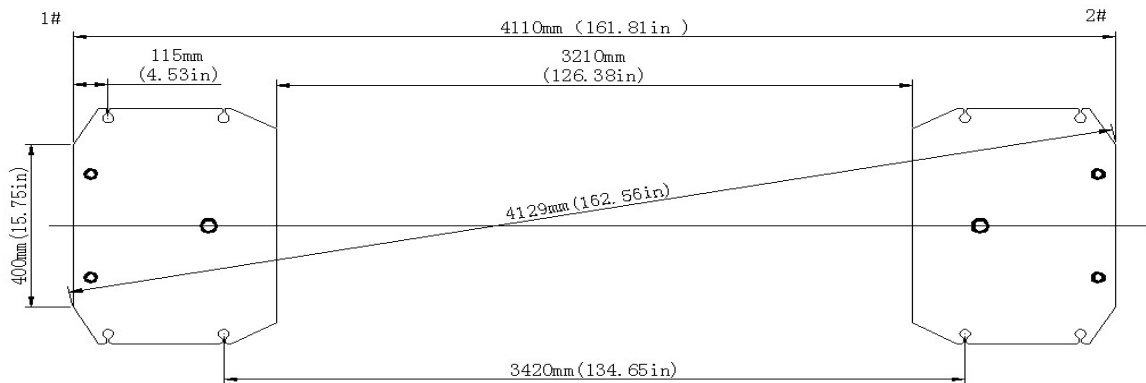
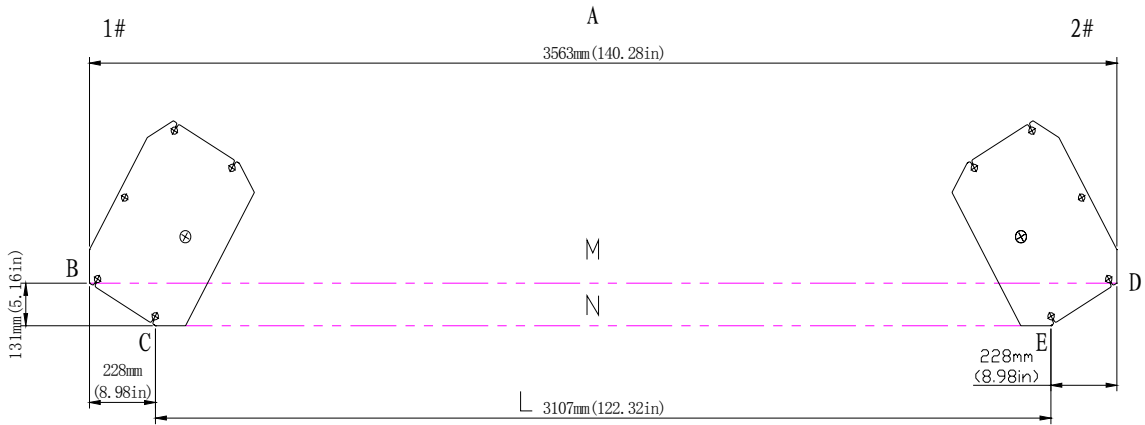

Fig 5b

TLT245AT base plate asymmetric installation is shown in 6a, TLT250AT (C) base plate asymmetric installation is shown in 6b

- With total width (A) as the basis, draw two parallel lines (#1 and #2) on the concrete slab, with the error within 3mm.

- Determine a point B at any point on chalk line #1, based on point B, move down 131mm, then move right 228mm to get point C. Based on point B, draw #1's vertical line M with a length of A to get point D. Based on point C, draw line M's parallel line N with a length of L to get point E. With four points B,C,D,E, each post's position can be decided.



F

Fig 6a

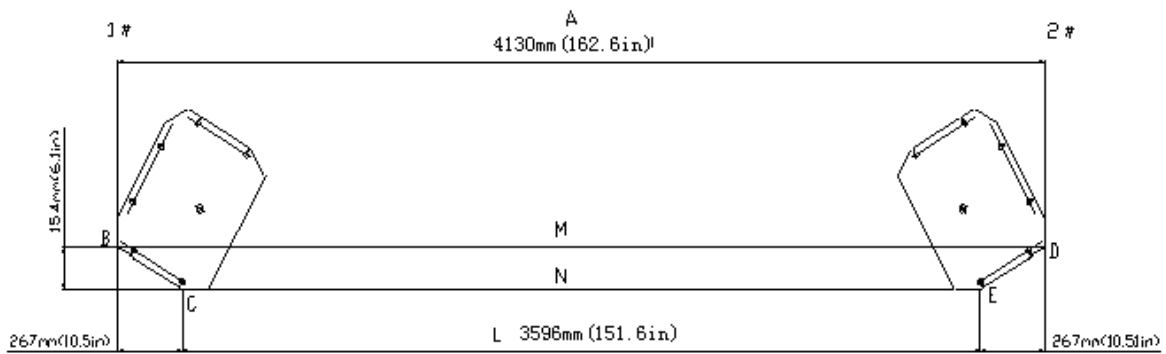

Fig 6b



Note:

- All the dimensions are based on the external border of the base plate.
- Ensure the overall error is controlled within 6mm. In this way, the difficulties in the final assembly can be eliminated.
- The marking and layout is very important. If it is inaccurate, there will be problems during the final assembly and operation.

### 5.2.3 Install the powerside column

First install extension column with column, then use lifting equipment to place power side column to the location as Fig.7 shows. Align the base plate of column with the chalk line layout. Guided by holes on the base plate of the column, use 5 concrete anchor bolts to fix it onto the ground. Drill and install anchor Bolt s at one time, during the drilling process, ensure no movement of the column.(Fig.7)

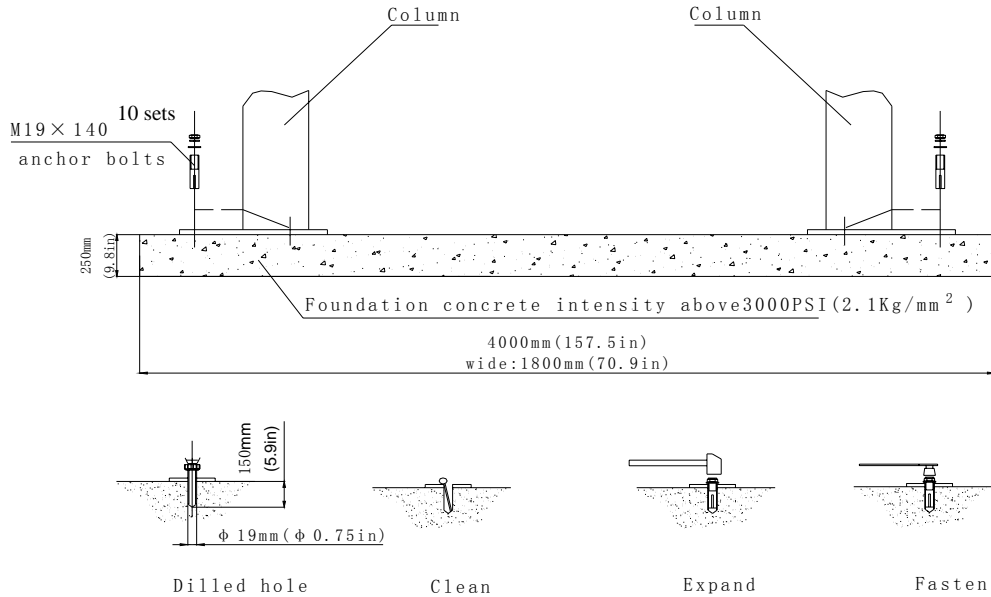

Fig.7



**Notes:**

- ◆ Use sharp  $\Phi 19\text{mm}$  concrete drill-bit to drill the holes so as not to drill the hole too large,. Use proper pneumatic tool to remove the dust from the hole. The depth of the hole is the same as that of the anchor Bolt . Insert the anchor Bolt and make the washers lean against the base of the column.
- ◆ When fastening the anchor bolt, only use the (torque) wrench, and don't use impact tool for fastening.

Insert proper steel shim under the base seat of column to plumb the column



**Note:** The thickness of shims shouldn't exceed 5mm.

To get the correct and safety installation, please follow the following installation steps.

- Wear the safety goggles
- Use hard alloy drill-bit.
- Don't use the drill-bit with wearing exceeding the tolerance.
- The drill and concrete surface should be kept

- perpendicular.
- Let the drill work itself. Don't apply the extra force, and don't ream the hole or allow the drill to wobble.
- The drilling depth of hole is based on the length of anchor Bolt .The distance from the Bolt head to the concrete floor should be more than twice of the Bolt diameter.
- Remove the dust from the hole.
- Gently tap the Bolt into the hole till the washer rests against the base plate of column.
- Fasten Bolt s

**5.2.4 Install the top beam**

Position the offside column at the designated chalk location. Lift the top beam to its high position, and use bracket and fasteners to fix it with the columns (as shown in Fig. 8). When installing the top beam, ensure the above micro switch support bracket adjacent to the power side column. In Fig 8:The symmetric top pulleys are to be installed at position 1、 1",asymmetric top pulleys are to be installed at position1、 1"、 2、 2"



**Note:** Since the offside column is not fixed to the ground, you must operate carefully to avoid the falling of the column.

Diagram of column, extension column and top beam

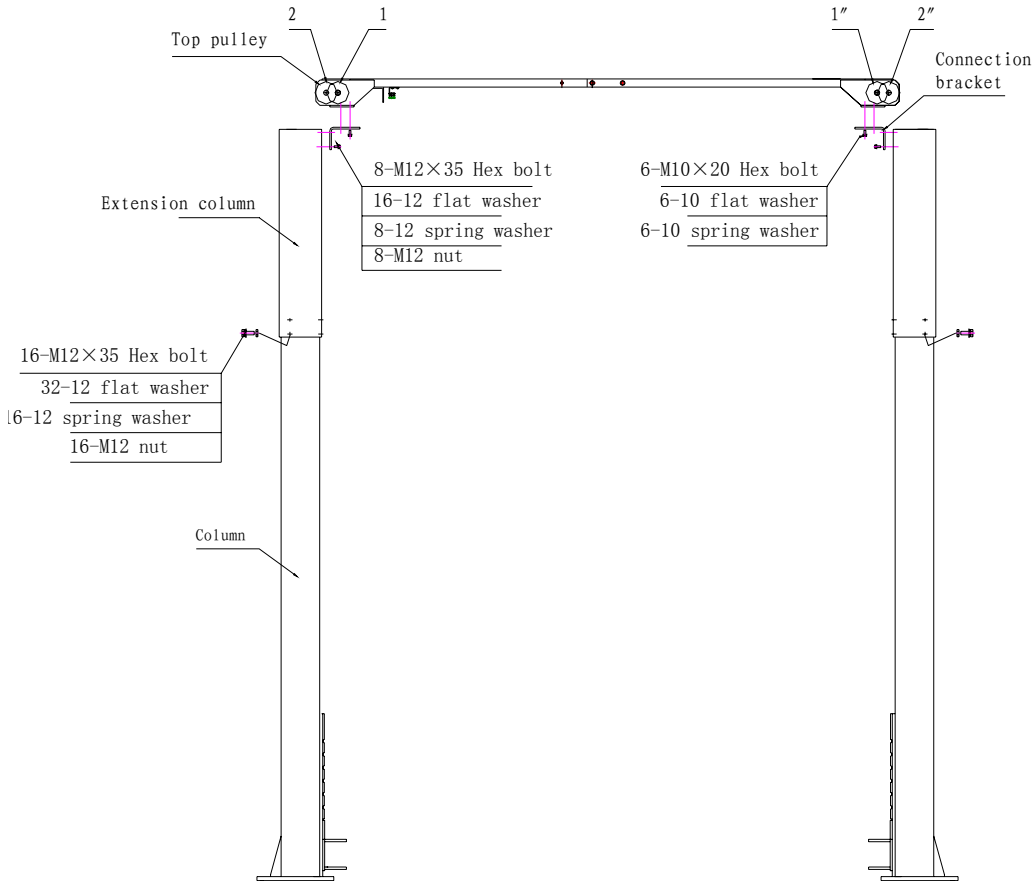

Fig 8

**5.2.5 Install the offside column**

Install the offside column as the procedures in 5.2.3.

**5.2.6 Install and adjust the balancing steel cables**

Raise the two carriages to the safety locking position and two carriages are of the same height from the floor. Install the two steel cables as shown in Fig. 9. Adjust the tension of cables through the adjustment nuts on each end of steel cable. The steel cables should be tight in

equal tension. Each steel cable should be ensured in the pulley when adjusting tightly, otherwise the steel cable will be damaged.



**Note:** Before operating the lift, recheck to balancing steel cables and ensure they are not intersected or wrongly installed. Ensure that the steel ropes are still on the pulley.

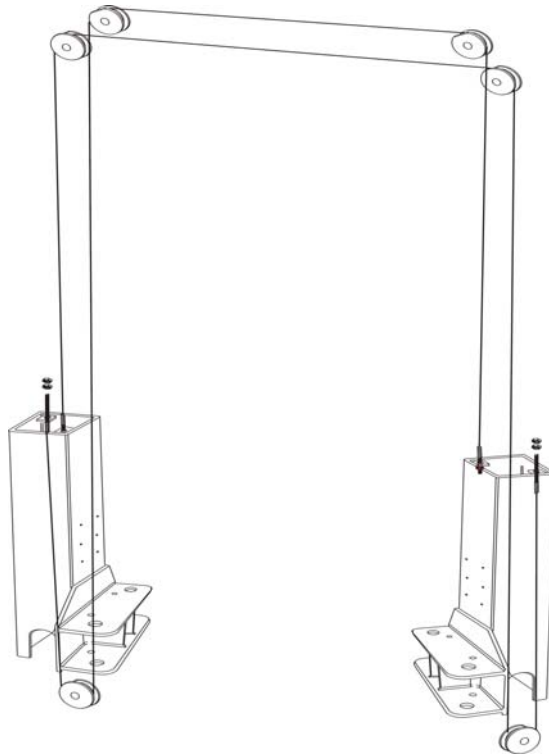

Fig 9

*Key points for assembly: the two steel cables shall be adjusted to equal tension in order to ensure the simultaneous movement of the two carriages.*

### 5.2.7 Install the power unit

Use two M10 bolts and washers to fix the power unit. After fixing the power unit, fill the reservoir with hydraulic oil. Operate carefully to avoid dust and other pollutants mixed with the hydraulic oil.

### 5.2.8 Connecting the power supply

Dismantle the sealing cover of the electrical box on the power unit and do the wiring according to the circuit diagram; the power supply switch is required to be installed near the lift for convenient disconnecting the power supply during maintenance or in case of emergency. The motor damage caused by wrong wiring is not warranted. Please contact the manufacturer for the electrical issues. Ensure that the oil tank is full; don't operate where there is no oil. After pressing the start button, if the motor doesn't run or the abnormal noise or heat occurs, the machine shall be immediately stopped to check the correctness of the electrical connections.

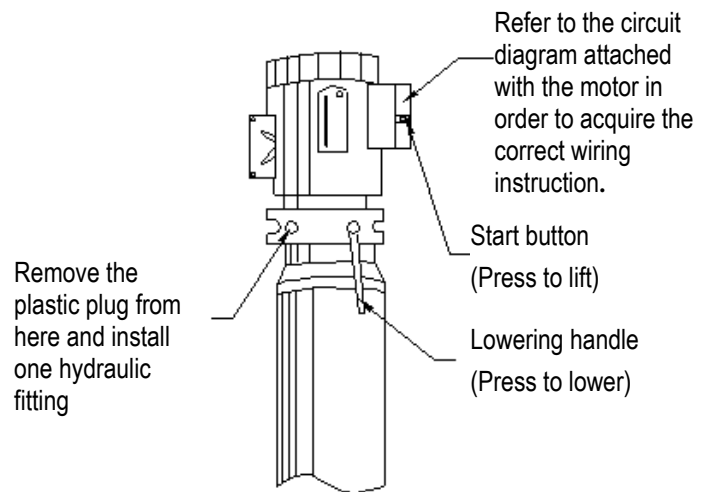

Fig 10



**Note:**

*If the lift is used outdoors, it is recommended to set a cover on the power unit; such damages to the motors. During the installation, rubber cushions must be added between the hydraulic station and the installation plate*



### 5.2.9 Lock release cable installation

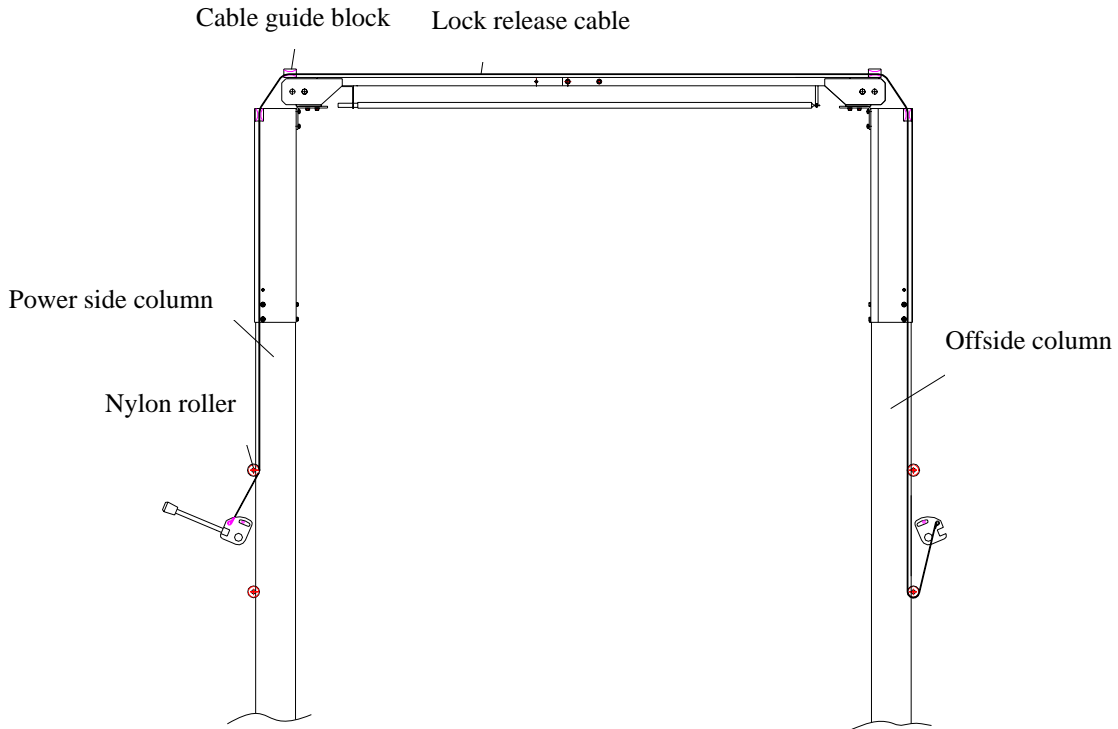

Fig.11

### 5.2.10 Connect the hydraulic lines

Hydraulic lines is shown in Figure 12; please perform the connection according to the diagram and all the fittings shall be tightened in order to prevent the oil leakage



*Note: When installing hoses, the carriage is at lowest position, to reduce the air in cylinder as*

*much as possible .Air bleeding is being conducted when debugging.*

*If the hose shall be installed through the column, ensure that the hose passage will not interfere with any moving parts.*

*Rubber cushions must be added between the hydraulic station and the installation plate.*

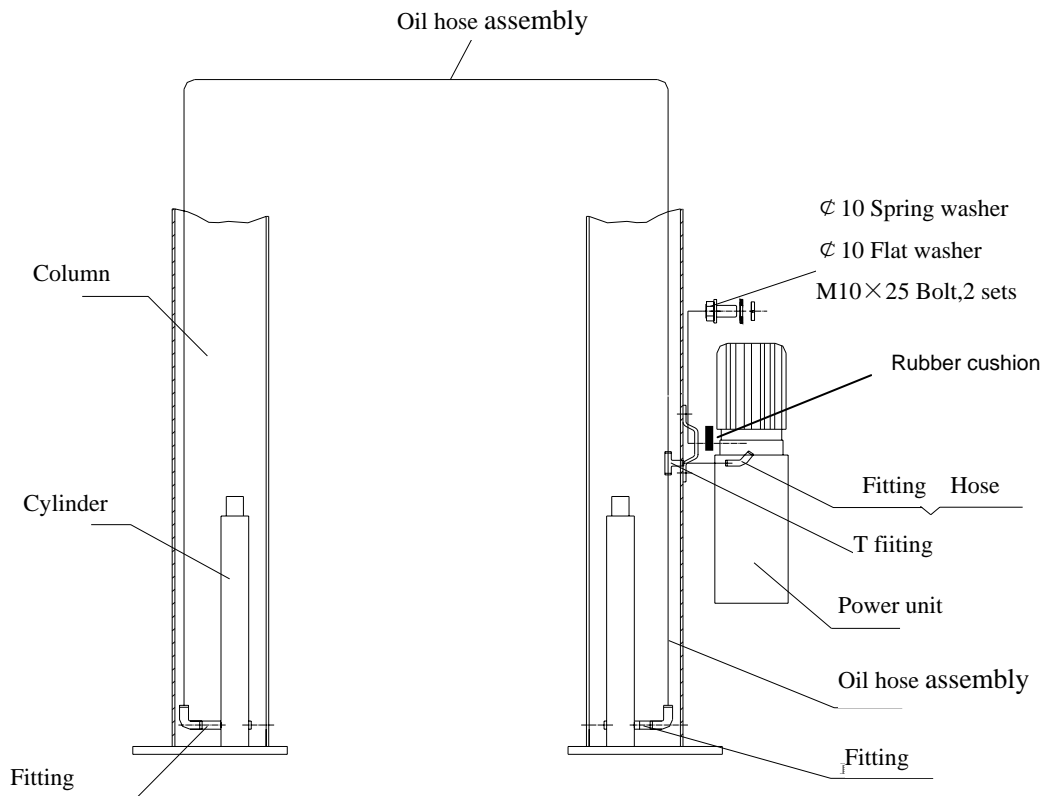

Fig 12a

When the finished product equipped with the pump station with base plate, loosen the 4 M6 screws on the column first, then install the pump station to the column through the anisotropic pore on the Motor mounting plate ,as the picture

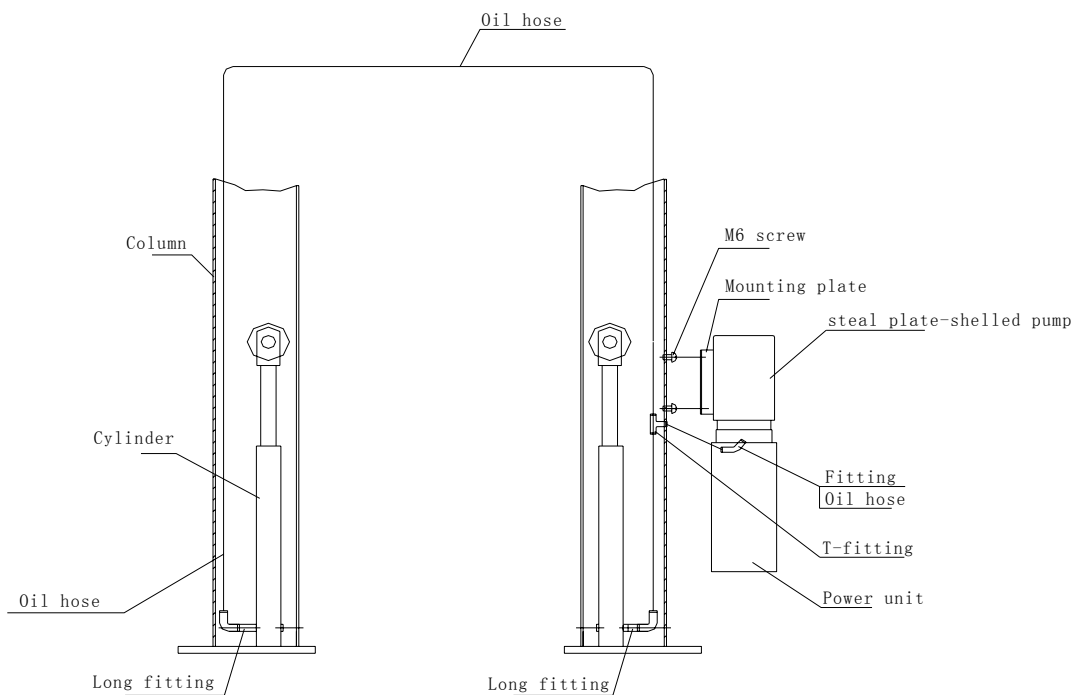

Fig 12b

below:

### 5.2.11 Install the swing arm

- Install the swing arm as Fig.13
- Check if the positioning gear mechanism at the end of arm fits, adjust the Screws of fixed semi-gear for its fitness.



*Note::*

- *During the installation, lubricate the moving parts of swing arm and carriage ,so that the swing arm can move freely.*
- *Make sure the arm positioning gear is engaged!*

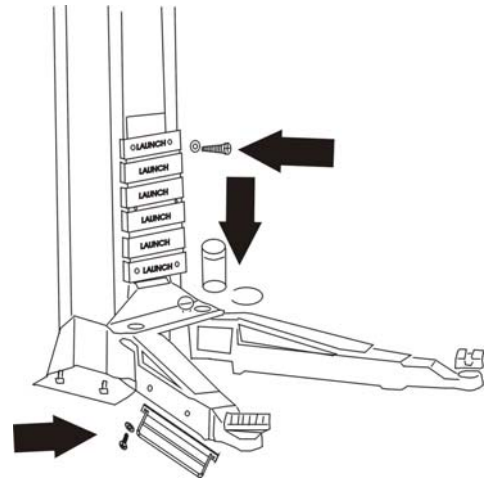

Fig. 13

## 6. Lift Adjustment

### 6.1 Preparation before the adjustment

- Lubricate contact surface of the carriage and corners of column with general-purpose lithium grease. All sliding surface should be coated evenly from top to bottom.
- Fill hydraulic oil N32 or N46 to the oil reservoir of the power unit.

### 6.2 Adjustment procedure

- Check to see if the power supply is installed properly
- Check for the tightness of all the connecting bolts.
- Press the start button on the motor, and the

carriage rises; stop pressing the button, then the carriage will stop. In order to lower down the carriage, first pull the safety lock handle on the column. If it can't be pulled, raise a little and pull again. At the same time press the lowering handle on the power unit and the carriage will be lowered; stop pressing the handle, then the carriage will stop. When repairing, after the vehicle is lifted up to the required height, first press the lowering handle to actuate the mechanical safety lock in order to ensure the safety operation.

- The hydraulic system may contain air due to new installation, to bleed the air, repeat the lifting and lowering for several time
- The adjustment is completed

## 7. List of the Lift components

This list is only used as the information for the maintenance and repair. Our company will not be liable for other uses. In case of damages to the components, purchase can be

made from the LAUNCH and its sales agents based on the corresponding material code No in the list.

### 7.1 TLT245AT components list

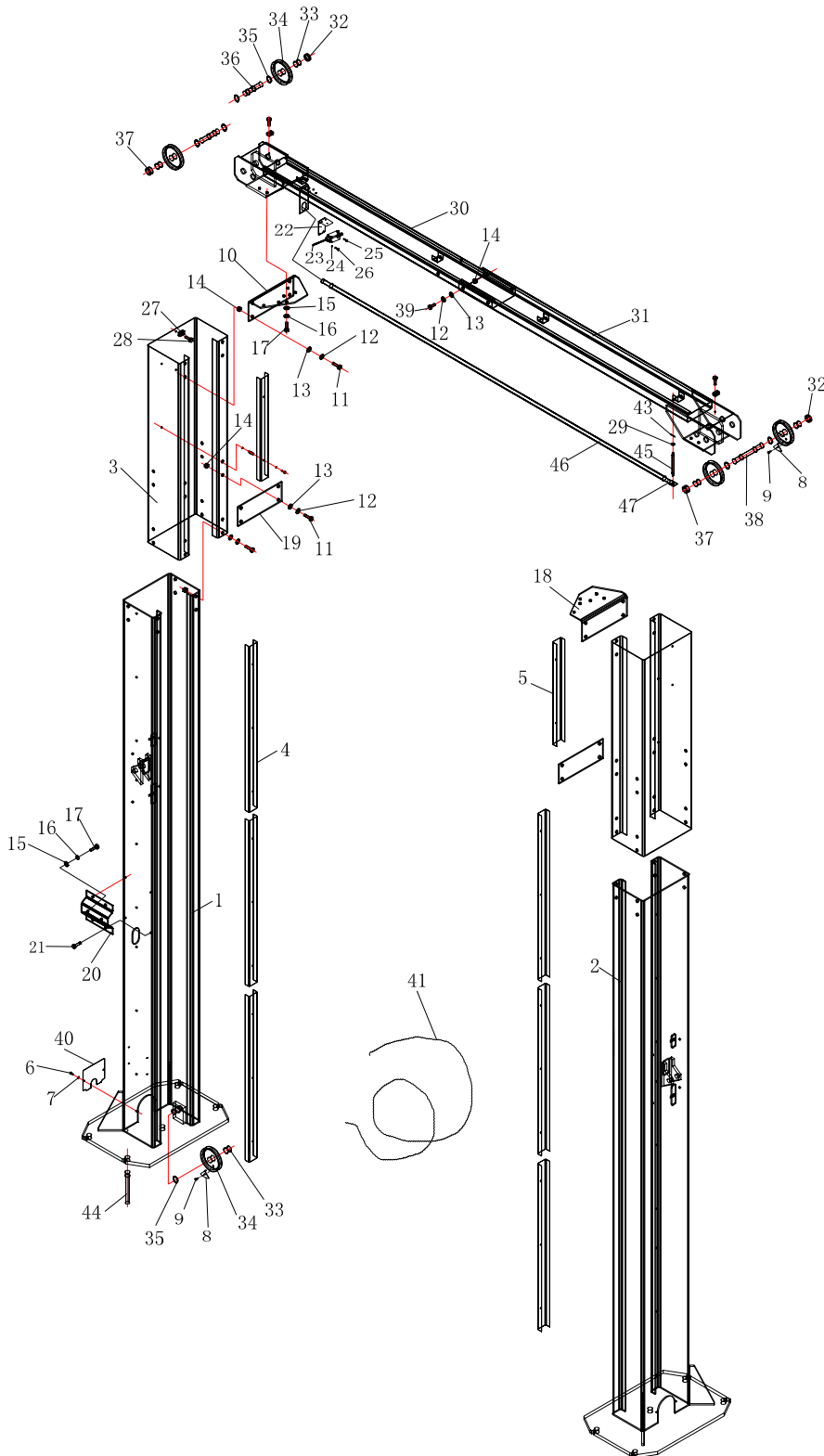

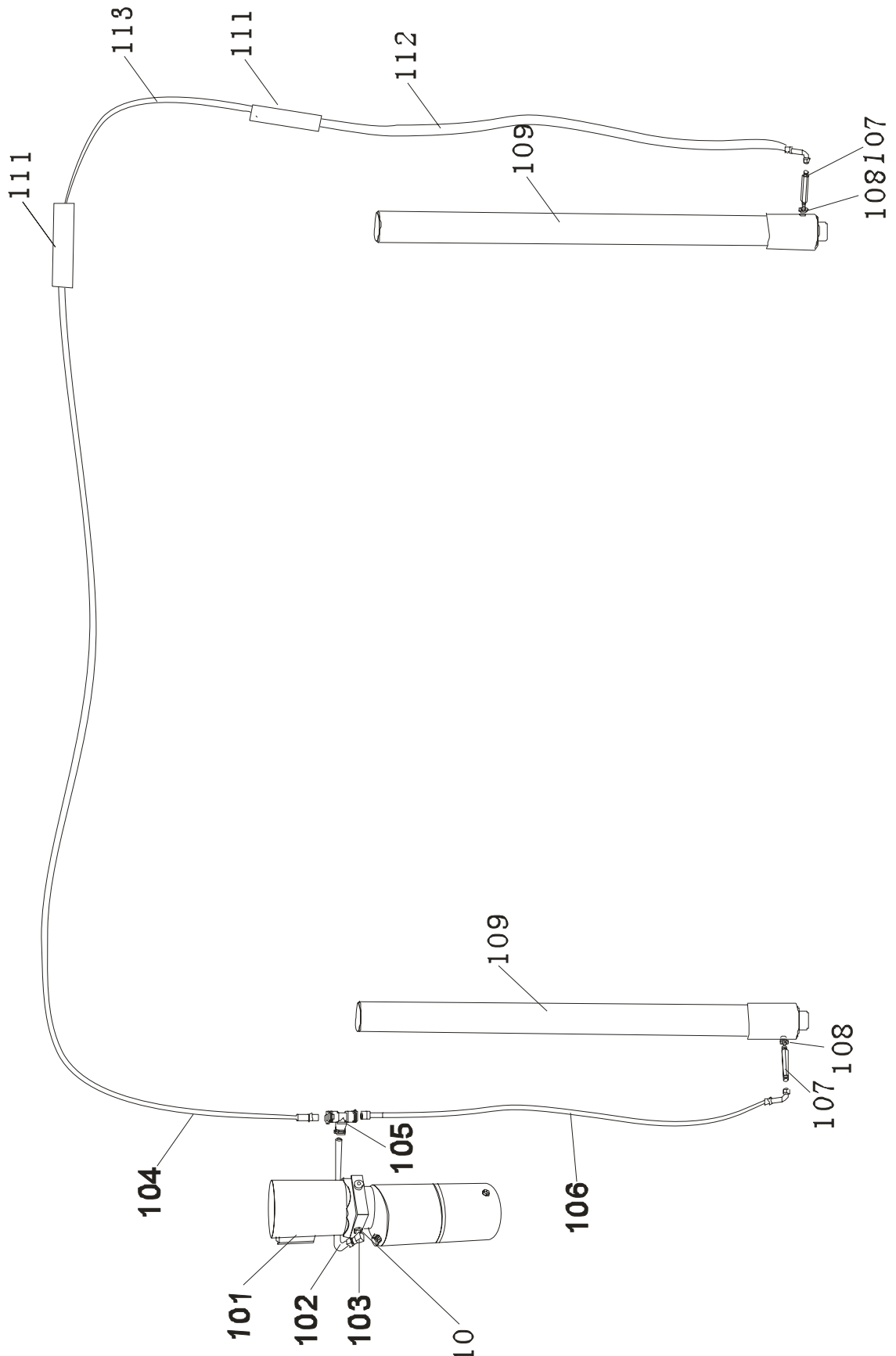

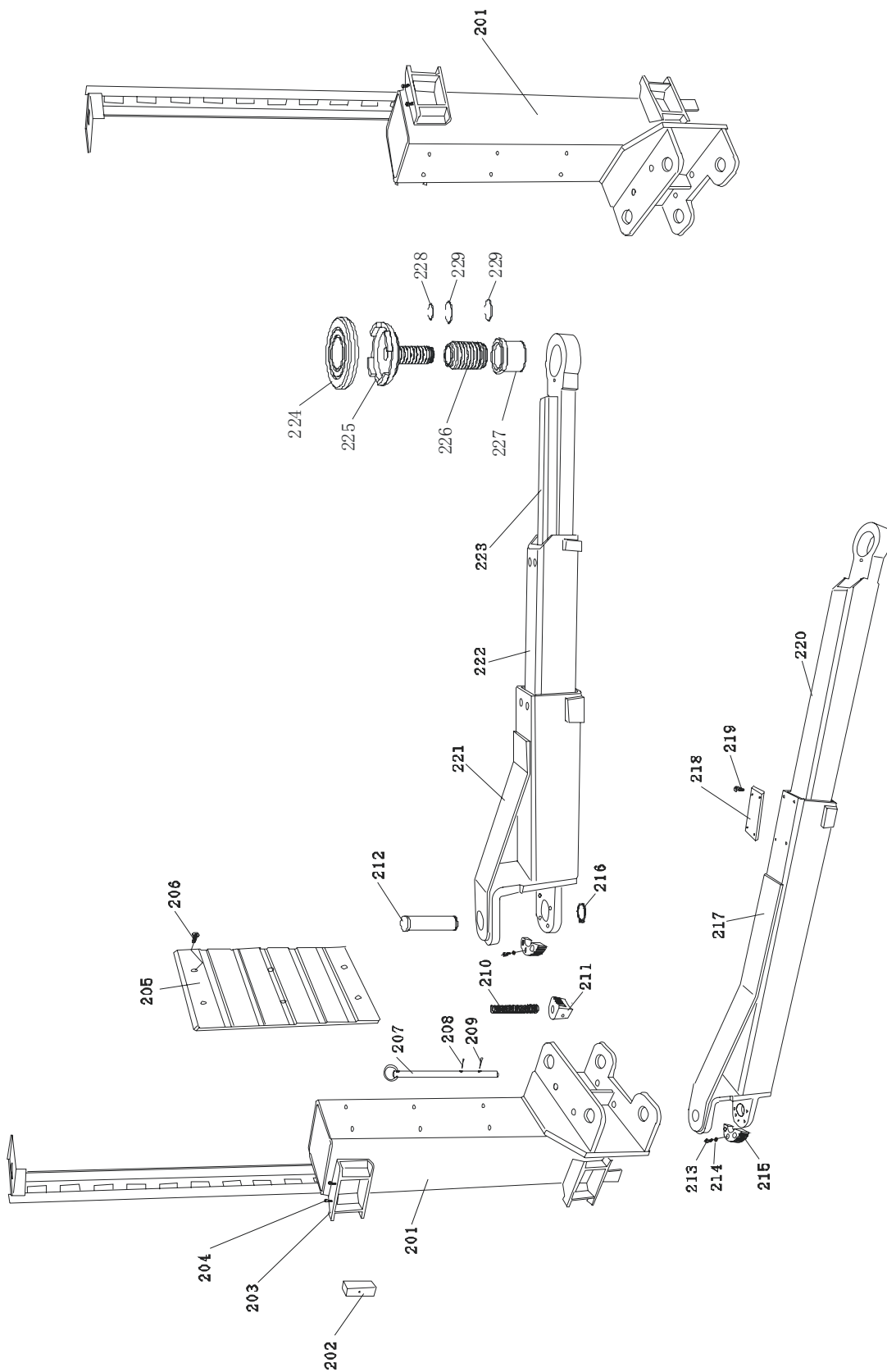

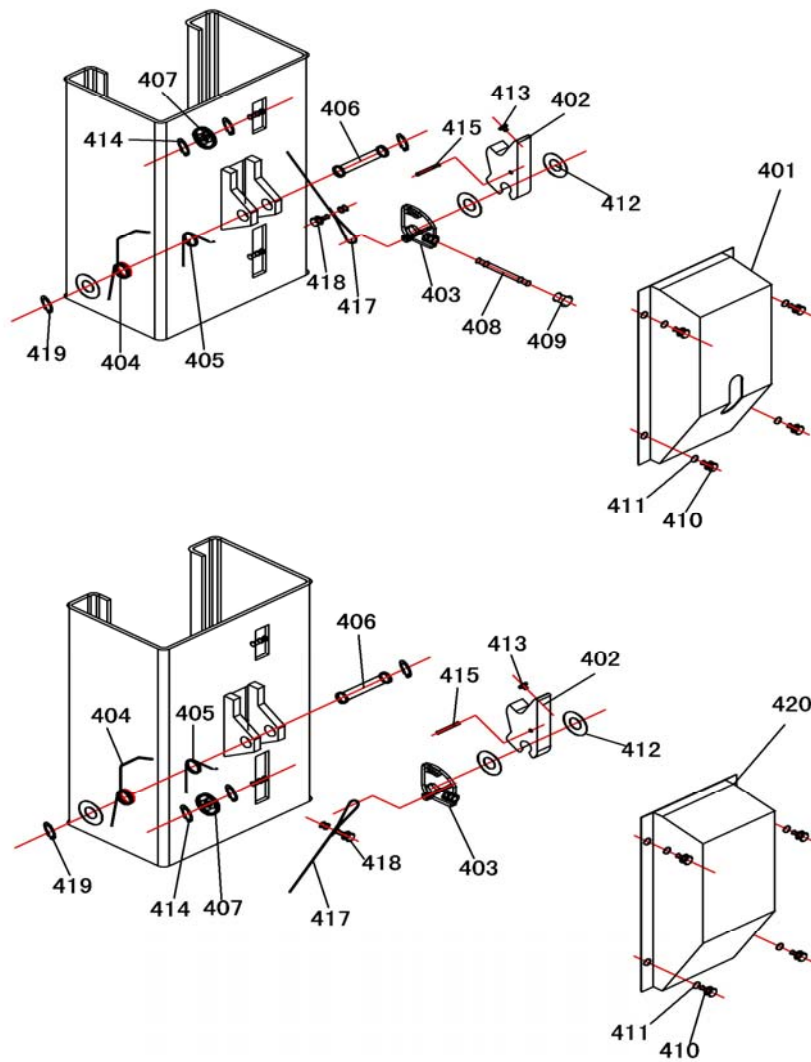

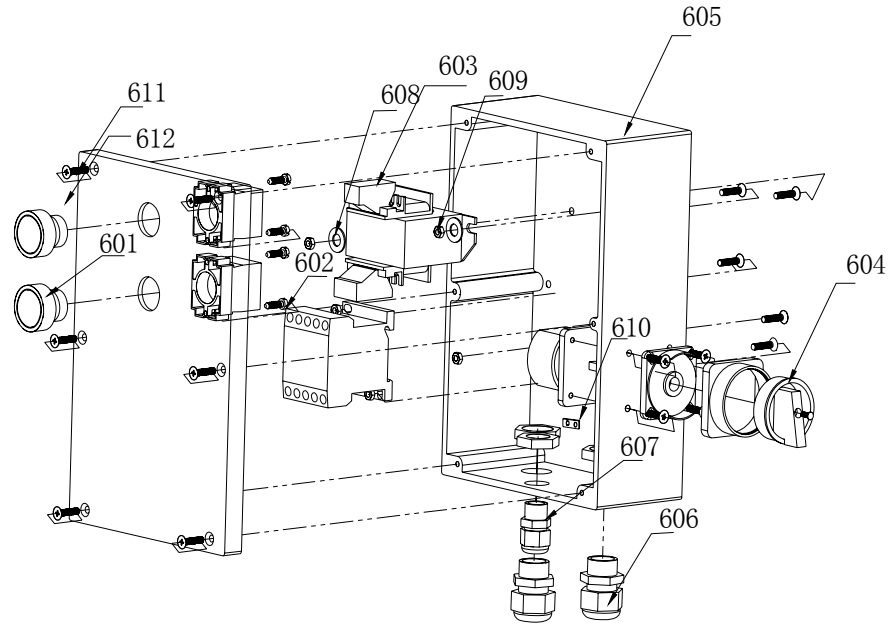

No.	Code	Name
1	201025108	TLT245AT power side column
2	201025109	TLT245AT offside column
3	201025112	TLT245AT extension column
	201025788	TLT245AT extension column(Lift height 4300mm/4150mm)
4	201025073	TLT245AT protective cover inside column
5	201025074	TLT245AT cover for extension column
6	103010498	Screw M5×8
7	103040132	Flat washer 5
8	103203019	Side positioning shim
9	103020188	Bolt M5*10
10	201025066	Connecting bracket I
11	103020104	Bolt M12×35
12	103040044	Spring washer 12
13	103040110	Flat washer 12
14	103030129	Nut M12
15	103040123	Flat washer 10
16	103040122	Spring washer10
17	103020038	Bolt M10×25
18	201025067	Connecting bracket II
19	201011176	TLT245AT reinforced bracket
20	201025083	Power unit bracket
21	103020190	Screw M6×10
22	103201545	TLT245AT bracket
23	102100075	Limit switch
24	103040109	Flat washer 4



25	103010426	Screw M4×12
26	103010429	Screw M4×25
27	201024606	Wire through block assembly
28	103020163	Bolt M6×25
29	103010134	Flat washer 8
30	201025069	TLT245AT inner top beam
31	201025070	TLT245AT outer top beam
32	103203324	Bushing I
33	103200699	Bushing 2520
34	103203017	Pulley
35	103050035	Returning ring 25
36	103200966	Asymmetric axle
37	103203325	Bushing II
38	103200967	Symmetric axle
39	103020126	Bolt M12×25
40	201011236	Bottom cover for column
41	103260338	TLT245AT steel cable
	103260346	Steel cable (Lift height=4150)
	103260364	Steel cable (Lift height=4300)
43	103060342	Pin 3×26
44	103020123	Anchor bolt M18×160
45	103203197	Supporting axle for long rod
46	104130196	Protective cover
47	103250270	TLT245AT long rod
101		Power unit
102	104120136	HP oil hose L=880
103	103100170	Fitting M14×1.5 (for domestic)
104	104120096	TLT245AT HP oil hose L=5370(Lift height=4300/3840)
	104120148	TLT245AT HP Hose L=6110(Lift height=4150)
105	103100172	T fitting
106	104120117	T fitting L=930
107	103201757	TLT245AT Flow-control fitting assembly
108	103040188	Seal gasket 18
109	102200321	Hydraulic cylinder
110	103040157	Seal gasket 14
111	103100198	Fitting
112	104120095	Oil hose of sub-cylinder
113	104120186	TLT245AT HP Hose L=920 (Lift height=4300)
201	201021316	TLT245AT Carriage
202	104990132	TLT245AT Sliding block
203	201025138	TLT245AT Top cover

204	103020215	Screw M10×25
205	104130191	Door rubber pad
206	103010539	Screw M8×12
207	103202184	Top rod assembly
208	103060346	Pin 5×40
209	103060342	Pin 3×26
210	103201914	Spring
211	103201744	Gear block
212	103202280	TLT245AT Pin axle
213	103011102	Screw M10×25
214	103040122	Washer 10
215	103201771	Semi-gear
216	103050030	Returning ring 40
217	201025047	TLT245AT Long rear arm
218	104130186	Rubber pad on arm
219	103010608	Screw M6×10
220	201021532	TLT245AT long front arm
221	201025045	TLT245AT rear arm
222	201024645	TLT245AT middle arm
223	201024646	TLT245AT front arm
224	104130315	Rubber pad
225	201021561	Screw assembly
226	103202107	Double adjustment screw cove
227	103202106	Supporting seat
228	103050091	Returning ring 30
229	103050090	Returning ring 45
401	104090074	Cover for safety mechanism
402	103203057	Safety block
403	103203056	Changing plate
404	103201450	Spring I
405	103201451	Spring II
406	103201455	Pin of safety block
407	103203055	Small pulley
408	103201454	Handle of safety release
409	103260186	Handle BM10×50 (black)
410	103010393	Screw M8×12
411	103040134	Washer 8
412	103203061	Adjustment washer I
413	104130210	Rubber pad
414	103050021	Returning ring 9
415	103060333	Pin 6X40
417	101060019	TLT245AT ∅ 1.6 steel cable

418	103260179	Steel cable clamp
419	103050025	Returning ring 20
420	104090073	Sub-cover for safety mechanism
601	102100074	Button, NB2-BE101, green color
602	102110059	Contactora(Shilin) ,S-P11,AC24V
603	102130043	Transformer, JBK-25,220V,380V/24V
604	102990109	Power switchLW39B-16RE04/-2-GR ( Small)
605	104090089	Waterproof Case, 240*160*90, (black)
606	102160391	cable joint PG13.5
607	102160388	cable joint PG9
608	103040109	Flat washer C class, GB/T95-1985,φ4(white zinc-plated)
609	103030009	Hex nut, GB/T6170-2000, M4(white zinc-plated)
610	103240319	ground copper bars
611	103030009	Screw , M4*18
612	102100090	Emergency stop button LA39-11Z/r

### 7.2 TLT250AT(C) components list

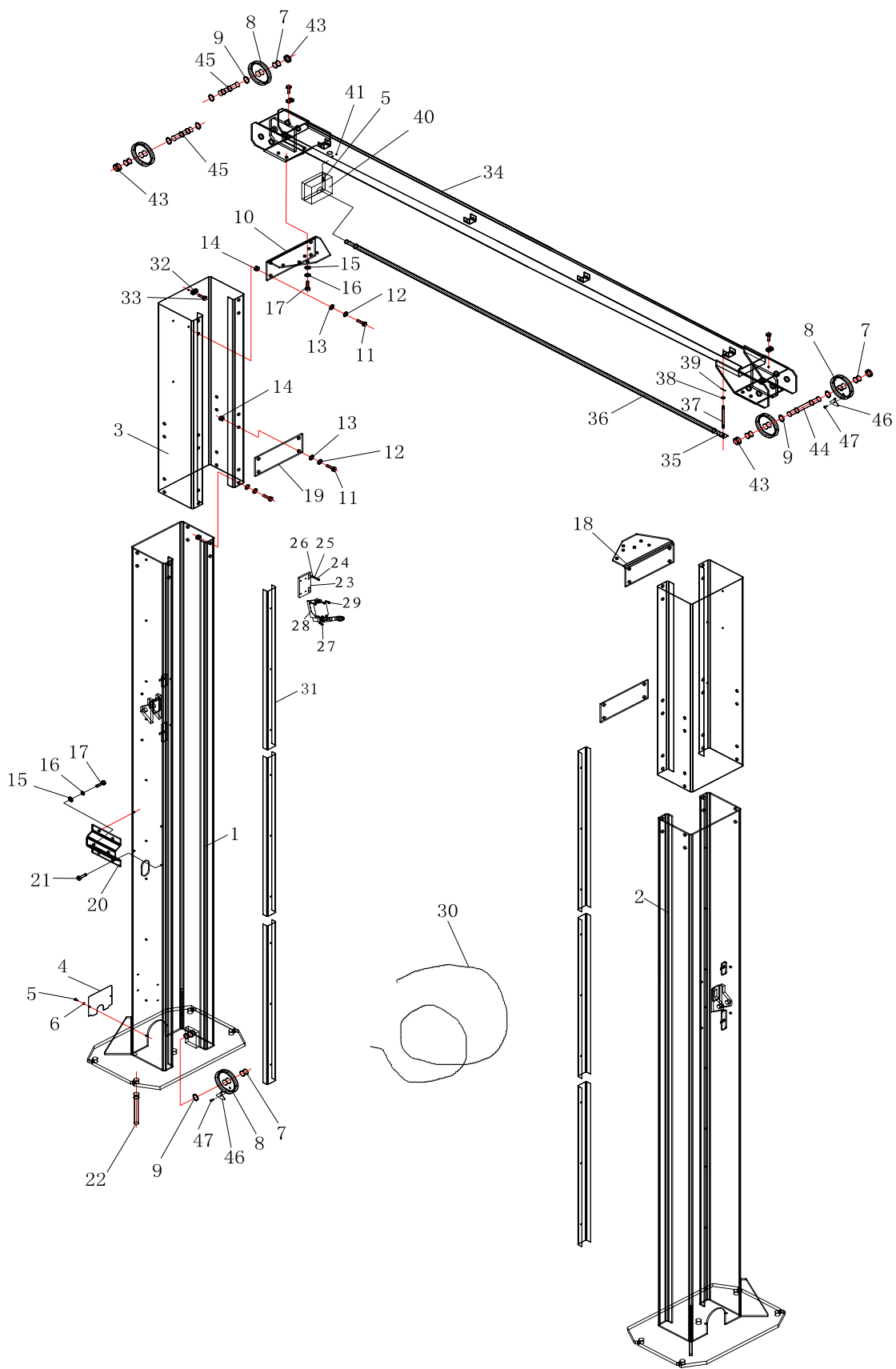

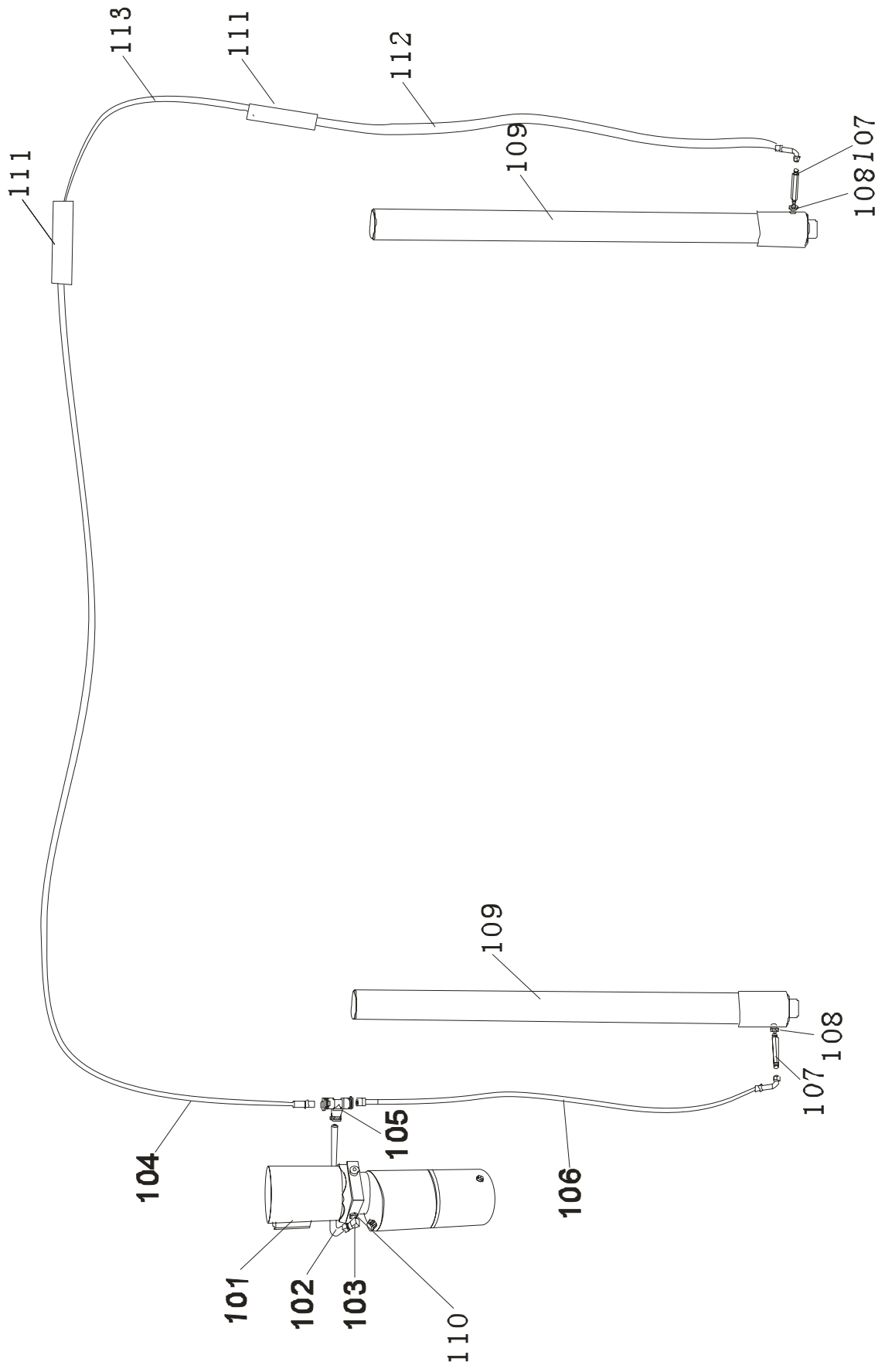

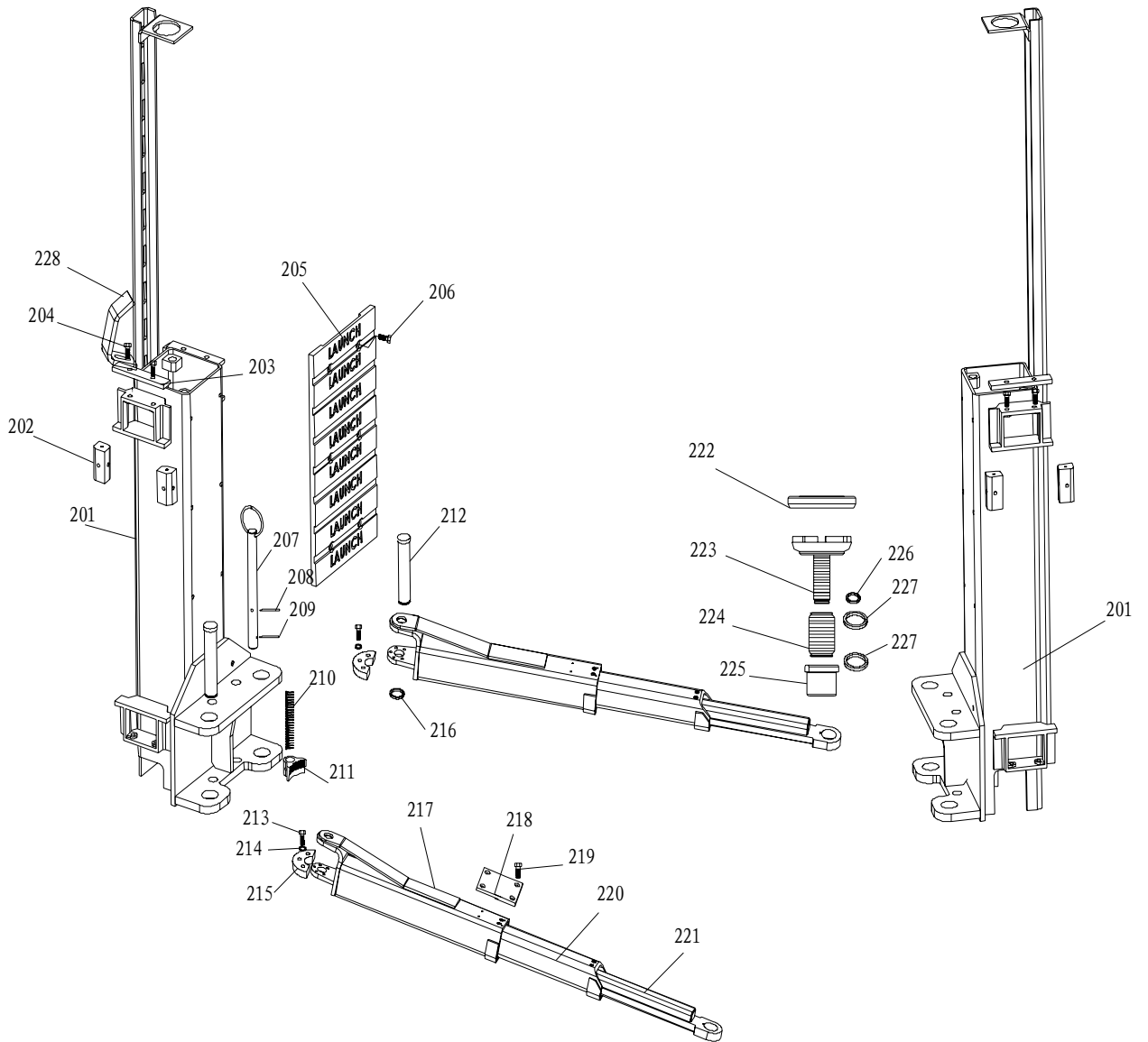

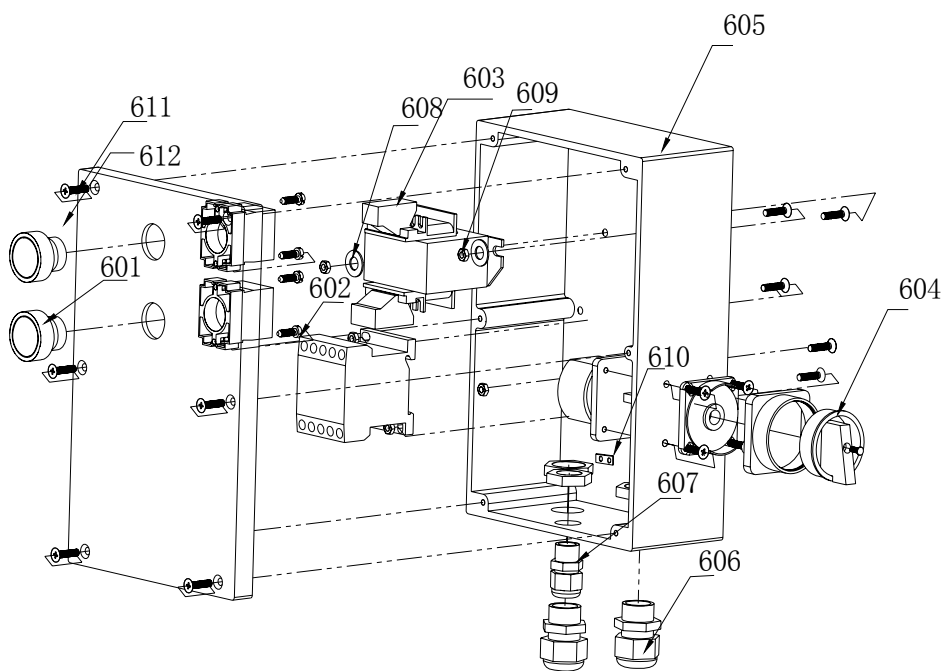
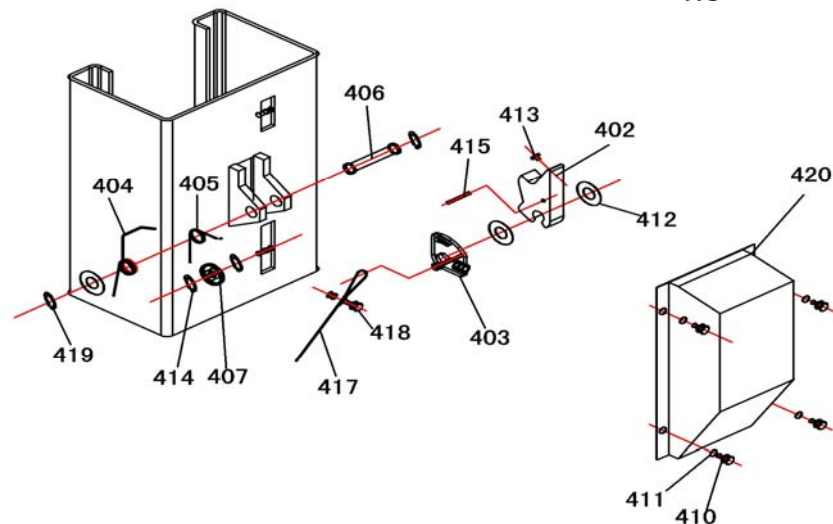
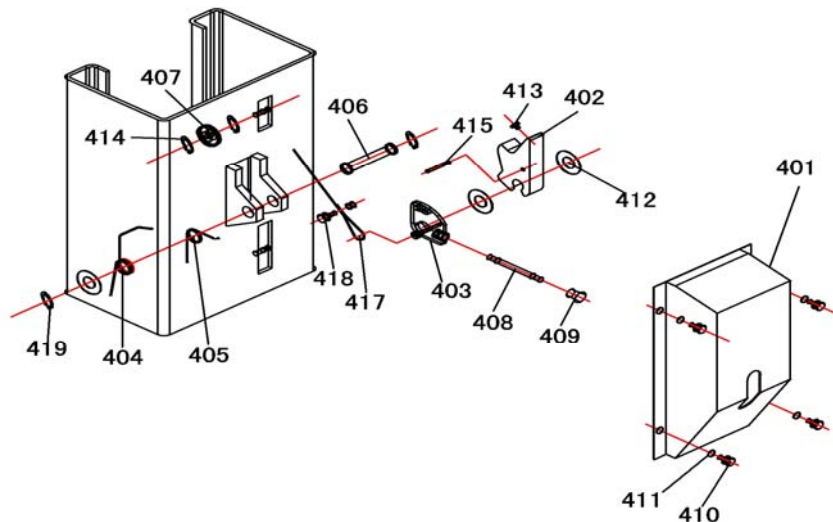

No.	Code	Name
1	201025110	TLT250AT(C) power side column
2	201025111	TLT250AT(C) offside column
3	201024792	TLT250AT(C) extension column
	201023637	TLT250AT(C) extension column(Lift height=4150)
4	201011236	Bottom cover for column
5	103010432	Screw M5×12
6	103040132	Flat washer 5
7	103200699	Bushing 2520
8	103203017	Pulley
9	103050035	Returning ring 25
10	201012493	TLT250AT(C) connecting bracket I
11	103020104	Bolt M12×35
12	103040044	Spring washer12
13	103040110	Flat washer 12
14	103030129	Nut M12
15	103040123	Flat washer 10
16	103040122	Spring washer10
17	103020038	Bolt M10×25
18	201012494	TLT250AT(C) connecting bracket II
19	201012138	TLT250AT(C) reinforced bracket
20	201025083	Power unit bracket
21	103020190	Screw M6×10
22	103020123	Anchor bolt M18×160
23	201014616	Limit bottom plate
24	103010437	Bolt M6×10
25	103040027	Spring washer6
26	103040133	Flat washer 6
27	103010429	Bolt M4×25
28	105990009	Limit switch
29	103010426	Bolt M4×12
30	103260349	TLT250AT(C) steel cable
	103260379	TLT250AT(C) steel cable(Lift height=4150)
31	201025073	Inner cover of column
32	201024606	Wire through block assembly
33	103020163	Bolt M6×25
34	201024940	TLT250AT(C) top beam frame
35	103250271	TLT250AT(C) long rod
36	104130196	busing (inner hole $\varnothing$ 22)
37	103203327	Supporting axle for long rod
38	103040134	Flat washer 8
39	103060342	Pin 3×26
40	108040166	TLT250AT(C)Top limit box assembly



41	103030018	Nut M5
43	103203325	Bushing II
44	103200967	Symmetric axle
45	103200966	Asymmetric axle
46	103203019	Side positioning shim
47	103020188	Bolt M5*10
101		Power unit ( optional )
102	104120136	HP oil hose L=880
103	103100170	fitting of pump (for domestic)
104	104120148	TLT250AT(C) HP oil hose L=6110
105	103100172	T fitting
106	104120117	HP oil hose L=950
107	103201847	TLT250AT(C) Flow-control fitting assembly
108	103040188	Seal gasket 18
109	102200321	Hydraulic cylinder
110	103040157	Seal gasket 14
111	103100198	Fitting
112	104120095	Oil hose of sub-cylinder L=4250
113	104120177	TLT250AT(C) HP hose L=1600 (Lift height=4810)
	104120187	TLT250AT(C) HP hose L=300 (Lift height=4150)
201	201021093	TLT250AT(C) Carriage
202	104990134	TLT250AT(C) Sliding block II
	104990135	TLT250AT(C) Sliding block I
203	201025139	TLT250AT(C) Top cover
204	103020215	Screw M10×25
205	104130267	Door rubber pad
206	103010555	Screw M8×12
207	103202184	Top rod assembly
208	103060346	Pin 5×40
209	103060342	Pin 3×26
210	103201914	Spring
211	103201744	Gear block
212	103202778	TLT250AT(C) Pin axle
213	103011102	Screw M10×25
214	103040122	Washer 10
215	103201771	Semi-gear
216	103050030	Returning ring 40
217	201024943	TLT250AT(C) rear arm
218	104130186	Rubber pad on arm
219	103010608	Screw M6×10
220	201024944	TLT250AT(C) middle arm

221	201024945	TLT250AT(C) front arm
222	104130315	Rubber pad
223	201021561	Screw assembly
224	103202107	Double adjustment screw cover
225	103202106	Supporting seat
226	103050091	Returning ring 30
227	103050090	Returning ring 45
228	201014617	Limit plate
401	104120103	Cover for safety mechanism
402	103203057	Safety block
403	103203056	Changing plate
404	103201450	Spring I
405	103201451	Spring II
406	103201455	Pin of safety block
407	103203055	Small pulley
408	103201454	Handle of safety release
409	103260186	Handle BM10×50 (black)
410	103010393	Screw M8×12
411	103040134	Washer 8
412	103203061	Adjustment washer I
413	104130210	Rubber pad
414	103050021	Returning ring 9
415	103060333	Pin 6×40
417	101060027	TLT250AT(C) steel cable,φ2.5mm,L=10m
418	103260179	Steel cable clamp
419	103050025	Returning ring 20
420	104120104	Sub-cover for safety mechanism
601	102100074	Button, NB2-BE101, green color
602	102110059	Contactactor(shilin) ,S-P11,AC24V
603	102130043	Transformer, JBK-25,220V,380V/24V
604	102990109	Power switchLW39B-16RE04/-2-GR (small)
605	104090089	Water-proof case, 240*160*90, (black)
606	102160391	Cable joint PG13.5
607	102160388	Cable joint PG9
608	103040109	Flat washer C class, GB/T95-1985,φ4(white-zinc plated)
609	103030009	Hex nut, GB/T6170-2000, M4(white-zinc plated)
610	103240319	ground copper bars
611	103030009	Screw , M4*18
612	102100090	Emergency stop buttonLA39-11Z/r

### Diagram of electrical system

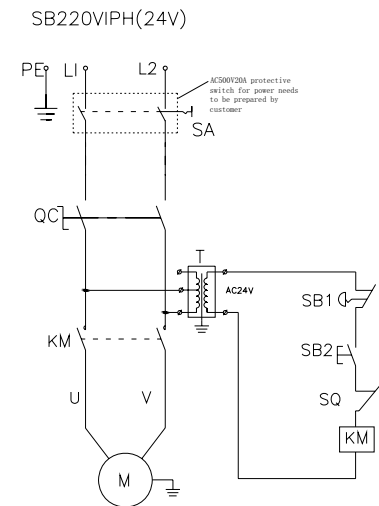

M–Motor KM–Contactor SB1–Emergency Stop Switch  
 SB2–Button SQ–Limit switch T–Transformer

Diagram of single-phase motor

The electrical working principle is as follows:

Press the start button (SB), motor (M) is energized to drive the gear pump supplying oil to push the carriage upward; release the start button SB, the motor (M) will lose

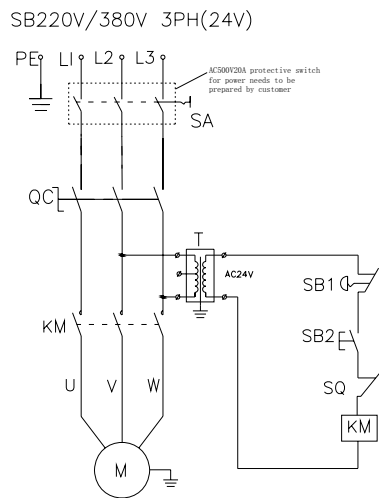

M–Motor KM–Contactor SB1–Emergency Stop Switch  
 SB2–Button SQ–Limit switch T–Transformer

Diagram of three phase motor

the power and the carriage will stop rising. if the vehicle is lifted up to the top and contacts the limit switch (SQ) on the top beam, the motor (M) will lose the power, the carriage will stop lifting to protect the roof.

**Diagram of hydraulic system:**

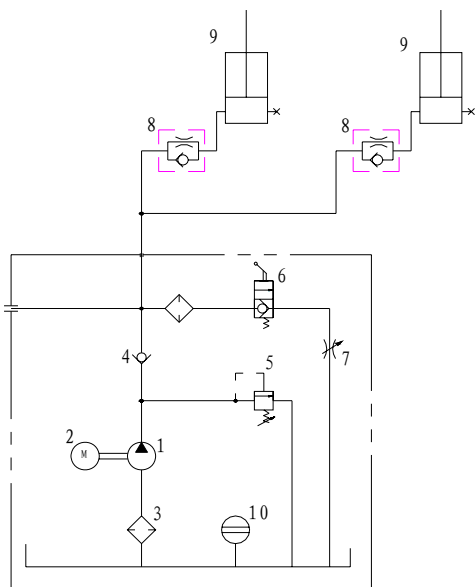

**Working principles of hydraulic system:**

When the button is pressed to start the motor on the power unit, the motor 2 will be actuated to put the oil pump 1 into motion; and oil will be sucked from the oil tank and sent to cylinder 9 forcing the piston move upward. At this time, the safety vale 5 is closed. (The pressure is well adjusted before leaving the factory to ensure the rated capacity. However, when the system pressure exceeds the limit, the oil will automatically overflow). When the start button is released, the oil supply will stop so as to stop the lifting. For lowering the carriage, first start up the motor to raise the carriage a little, pull the safety lock handle on the colum to disengage the safety locking status; and then press the manual lowering handle valve 6 to lower the carriage.

**Appendix: Transportation Guide**

- TLT245AT clear-floor two post lifts has 5 pieces of packaging.: 1# Angle iron bracket packaging. 2# cardboard box packaging. 3# top beam packaging, 4# and 5# extension column packaging. TLT250AT (C) clear-floor two post lifts has 3 pieces of packaging: 1# Angle iron bracket packaging. 2# cardboard box packaging. 3# top beam packaging. The metal surface of product in package is wrapped with plastic bubble bag and cardboard. Transportation guide is

printed on packing (See Figures below)

- While using forklift to lift the 1# packaging, the fork arms must be of same distance from the center of the packaging and the distance between two fork arms should at least be 700mm .While using a forklift to pick up goods, the forks should get into the area below them as deep as possible. The goods should not be touched by fork tips or pushed by them. Product damages caused by collision or high piling should be avoided

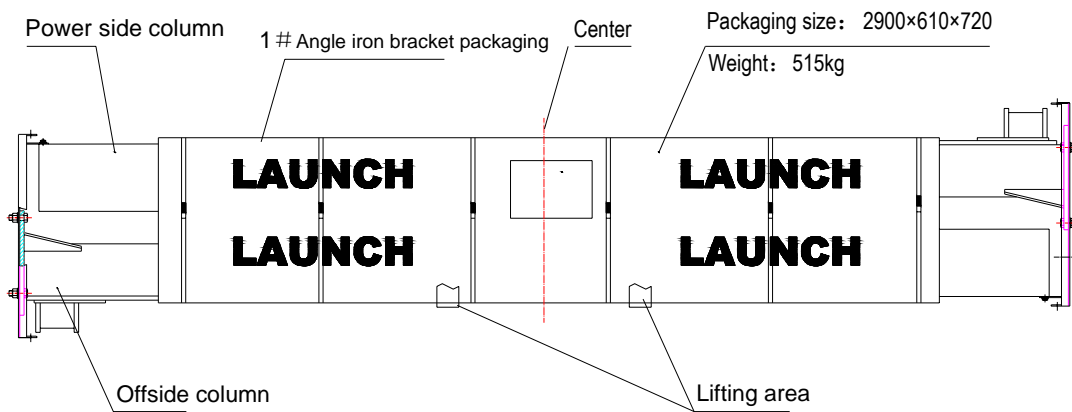

1 # Angle iron bracket packaging ( TLT245AT )

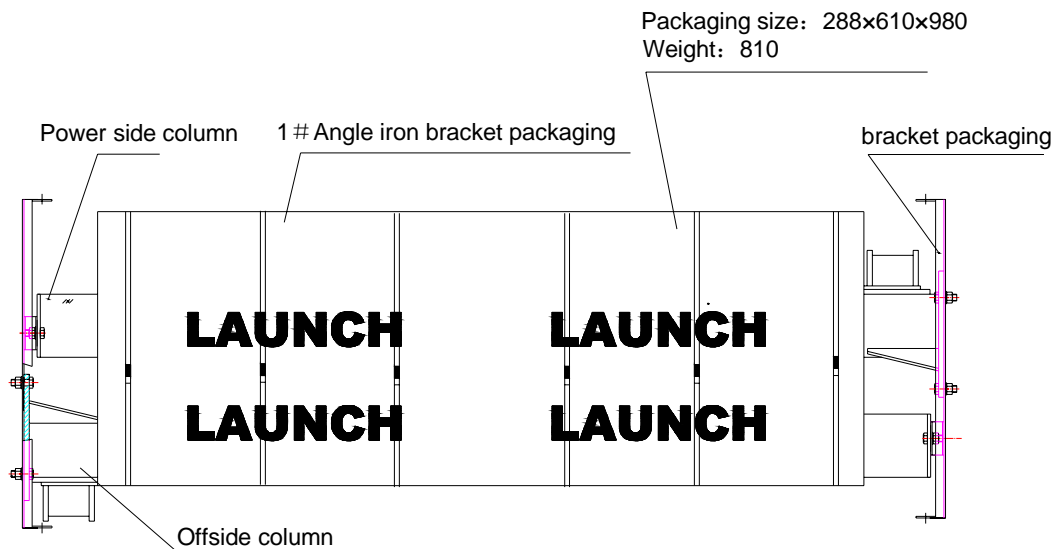

1 # Angle iron bracket packaging ( TLT250AT ( C ) )



Client: LAUNCH SHANGHAI MACHINERY CO., LTD.  
NO. 661 BAI'AN ROAD,  
ANTING,  
JIADING,  
SHANGHAI,  
P. R. CHINA.



SGS

SGS United Kingdom Limited  
Unit 10  
Bowburn South Industrial  
Estate  
Bowburn  
Durham  
DH6 5AD

Page 1 of 1

## CERTIFICATE OF ADEQUACY

Certificate No MDC 1074

SGS United Kingdom Ltd is a Notified Body appointed by the DTI under the Machinery Directive 2006/42/EC.  
Appointment Number 0890.

Date of Issue: 13<sup>th</sup> March 2013

SGS Reference: CST173505/1/TF

Details of Product: Two post lift (Vehicle lift)

Models: TLT235SB; TLT235SBA; TLTE32SBA; TLT235SBA(E);  
TLT240SB; TLT240SBA; TLTE40SBA; TLT235SC;  
TLT235SC(U); TLT235SCA; TLT235SCA(U); TLTE32SCA;  
TLT240SC; TLT240SCA; TLTE40SCA; TLT245SCA;  
TLT240AT; TLT245AT; TLT250AT.

Technical File Ref. No: CST173505/1/TF (OUCE12659)

Date of Assessment: 7<sup>th</sup> - 12<sup>th</sup> March 2013

Assessment Performed: Assessed for compliance with the requirements of Annex V  
of the Machinery Directive 2006/42/EC (Technical File).

Conclusion: In the opinion of SGS the submitted technical file referenced as  
CST173505/1/TF (OUCE12659) satisfies the requirements of the  
Machinery Directive 2006/42/EC.

Issue No. 1 Valid until 12<sup>th</sup> March 2018

*This certificate refers only to the sample submitted for test. This certificate shall not be reproduced except in full  
without the written approval of SGS United Kingdom Limited.*

*The CE mark as shown below can be used, under the responsibility of the manufacturer, after completion of an  
EC Declaration of Conformity and compliance with all relevant EC Directives.*



Authorised Signatory

*F. Huggins*



F. Huggins  
Principal Test Engineer

All enquiries relating to this certificate must be directed to the Test Engineer

This document is issued, on the Client's behalf, by the Company under its General Conditions of Service printed overleaf.  
The Client's attention is drawn to the limitation of liability, indemnification and jurisdiction issues defined therein.

Any other holder of this document is advised that information contained herein reflects the Company's findings at the  
time of its intervention only and within the limits of Client's instructions, if any. The Company's sole responsibility is to  
its Client and this document does not exonerate parties to a transaction from exercising all their rights and obligations  
under the transaction documents.

Doc. MDT:02\_iss\_5\_01/05  
F077301

SGSPAPER  
11999482

